

# **Linking brand equity and customer equity: A system dynamics perspective.**

**Ariel Nian Gani**

Radboud University Nijmegen, Netherlands

**Andreas Größler**

Associate Professor

Radboud University Nijmegen, Netherlands

## **Abstract**

Customer equity and brand equity are two important concepts in the current debate among marketing researchers and practitioners. This research attempts to conceptualize the linkage between brand equity and customer equity from a system dynamics perspective. While isolated models for both concepts exist, they are usually highly abstract and hard to operationalize in day to day marketing management. Conceptualizing the linkage between brand equity and customer equity explicitly in a system dynamics model provides insights on how these two concepts interact with each other and, thus, improves the marketing management decision-making process. This research engages well-known hierarchy of effect models (AIDA and ATR) to investigate the customer development chain related to brand equity and customer equity. The resulting system dynamics model is tested with a variety of initial settings and policy options.

Keywords: Brand equity, Customer equity, AIDA, ATR, System Dynamics

## **1. Introduction and research objective**

Recent years have seen an increased emphasis on customer-focused marketing approaches. In particular, much interest in marketing has centered on the concepts of brand equity and customer equity. However, there has been relatively little attention paid to reconciling the relationship between these concepts (Ambler et al., 2002). Many academic researches proclaim that the customer asset can be a company's most valuable asset and they should do everything in their power to create and sustain customer equity. Similarly, other researches also argue that brand is "the thing" which must properly be built and so that companies can leverage their brand equity. Although these two marketing concepts

have different perspectives, they are not totally separated from each other. A study explains the linkage between these two concepts as there are no brands without customers and there are no customers without brands (Leone, Rao, & Keller, 2006). The two concepts can have an interactive effect such that marketing actions can improve customer equity that then improves brand equity and vice versa (Keiningham, 2005). Before proceeding, it should be noted that brand equity is defined as value of having a well-known brand name, not as how much Dollar value a brand is worth (Aaker, 1995). On the other hand customer equity is defined as the Dollar value of an asset, in this context the Dollar value of customer base. This major difference is the source of much confusion because these two concepts have different units of measurement (Ambler et al., 2002). Nevertheless, there is previous research that examined both concepts and their relationships such as linking both concepts on conceptual model (Leone et al., 2006) or that studied the impact of brand equity on key elements of customer equity (Stahl & Heitmann, 2012).

Most of this research based on conceptual models is hard to operationalize in marketing management. For example, how can brand equity explain the development of customer behavior in a company? Or, how can the development of customers' behavior determine the value of customer equity? To answer these questions, we will operationalize the concept of brand equity and customer equity. Thus, the two concepts are conceptualized and operationalized from the perspective of customers' behavior. For many years marketing practitioners and academics have been discussed a "hierarchy of effect" on marketing effectiveness and customers behavior. The so-called AIDA chain, an acronym for Attention, Interest, Desire and Action (Barry, 1987), is still one of the most referred to "hierarchy of effect" models in the marketing literature concerning how customers behave in responding to marketing activities because it represents the actual operational customers behavior on the real world (Barry, 1987). AIDA chains capture the process of customer behavior until they purchase the product; however, it didn't capture the post-consumption effect. Another "hierarchy of effect" model which incorporates the post-consumption phase is ATR, an acronym for Attention, Trial and Reinforcement/Repurchase (Ehrenberg, 1974). These two hierarchy models capture the operational perspective of customer behaviors toward purchase and repurchase. Based on the function and purpose of the model, AIDA and ATR models are suitable to conceptualize the linkage between brand equity and customer equity from a system perspective.

A system-based analysis to linking brand equity and customer equity using the system dynamics (SD) modeling approach not only provides a comprehensive picture to better understand the interactions between both concepts but will also be practical for marketing's operational

implementation. One of the expected outcomes of the research is using SD methodology to provide a differentiated approach to linked brand equity and customer equity. This approach will determine the relationship between the two concepts in term of an SD perspective, thereby contributing to the body of knowledge about this topic. On the other hand, by engaging SD to links the two concepts will give additional insights of how these two concepts operate in practical marketing management.

The objective of this research is to engage the AIDA and ATR chains to study the linkage of brand equity and customer equity by examining current academic conceptual models of both concepts and then constructing a comprehensive SD model to provide a contribution on the interactions of both concepts. The operational perspective of the SD model will be illustrated by a case study of a capital goods company through behavioral analysis. (This last part will only be available at the time of the conference).

The research questions which will be addressed are:

1. To what extent is the AIDA-ATR chain model able to conceptualize the linkage between brand equity and customer equity?
2. How can the linkage of brand equity and customer equity be described using a system dynamics model?
3. To what extent does the case study confirm the insights provided by the system dynamics model? (Not yet covered in this paper; will be available at the conference).

## **2. Literature review**

### **Brand equity**

Brand equity is a phrase in marketing which describes the value of having a well-known brand name. The reasons are because a well-known brand can generate more money compare to a less well-known name, and customers believe that a product with a well-known name is better than product with less known names (Aaker, 1995; Keller, 2003). By definition brand equity is a set of categories of brand assets and liabilities linked to a brand, that add or subtract the value provided by a product/service to a firm's customers (Aaker, 1995). Another definition called customer-based brand equity defined brand equity as the differential effect that customer knowledge about a brand has on their response to marketing activities and programs for that brand (Keller, 2003). These two definitions of brand equity have different strengths and weaknesses (Ailawadi, Lehmann, & Neslin, 2003). These two definitions provide insights for strengthening brand equity but they provide little information about brand performance in term of market share and profitability (Stahl & Heitmann, 2012). There are three

categories to measures in brand equity which are customer mind-set, product market and financial market (Ailawadi et al., 2003). The advantage of having three divide categories on measuring brand equity is that not only rely on customer judgments but also actual purchase data on the market and Dollar value of the brand (Ailawadi et al., 2003).

Based on the definitions suggest that brand equity focuses on how the customers see the characteristics of a company. To assume that customers recognize the characteristics of the company then is to assume that there are interactions between brand and customers (Tim Ambler & Bhattacharya, 2002). The clear implication of these interactions is that brand is one of the most important intangible assets of a company (Leone et al., 2006). As the result of how important the role of brand in company firm, many different academic and marketing consultancy models of brand equity have been proposed in recent years. There are two types of brand equity models, practices oriented and academic models. Brand equity models use on marketing practitioners and consultancies are Young and Rubicam's Brand Asset Valuator (BAV) and Millward Brown's Brand Dynamics model. The two most widely use of brand equity models in academic field are Aaker's model (Aaker, 1995) and Keller's model (Keller, 2003). This research focuses on the academic brand equity model. Aaker's model proposed that brand equity as a set of five categories of brand assets and liabilities linked to a brand. These categories are brand loyalty, brand awareness, customer perceived quality, brand associations and other proprietary assets (Aaker, 1995). These assets categories provide various benefits and value to firm. Aaker's model captured the measurement of customer mind-set and product performance on the market but this model lack of measurement criteria on financial market. On the other hand, Keller's model refers brand equity as the knowledge of brand in all the thoughts, feelings, perceptions, images and experiences that become linked to the brand in the minds of actual or potential customers (Keller, 2003). Keller's model only focuses on customer mind-set to measure brand equity. Keller's model imperatively suggests that any customer mind-set measure of equity include both awareness and brand associations (Stahl & Heitmann, 2012).

The most important components of brand equity are brand awareness and brand image (Leone et al., 2006). Brand awareness is related to the strength of brand being recall or recognize by customers under different conditions. Brand image is defined as customer perceptions and preference toward of a brand as reflected by the various types of brand associations held in customers' memory. Brand awareness and brand image are important as sources of brand equity to drive customer behavior such as customer attention, interest, desire and purchase (Leone et al., 2006). The benefits of having strong brand equity to customer behavior are greater loyalty, less vulnerability to competitive marketing

actions, larger margins, more elastic customer responses to price change (increase/decrease), expand growth opportunities from brand extensions (Leone et al., 2006). Aaker's model captured most of the important components of brand equity therefore Asker's model of brand equity is the most suitable to use on operationalize the concept of brand equity.

### **Customer equity**

The concept of customer equity is built in the regard that companies have to formally define and manage the value of their customers. The importance to know of how much value its customer base in terms of future revenues is the basic idea of customer equity. Customer equity is defined as the Dollar value of an asset, customer equity is a financial measure that has immediate application as a metric for assessing customer prospect, as an objective to be managed, and as a method for valuing a company (Gupta, Lehmann, & Stuart, 2004). A general definition of customer equity is in terms of the sum of lifetime values of all customers (Rust, Lemon, & Zeithaml, 2004). A customer equity perspective focuses on the customer thinks of the brand. Customer knowledge in the form of perceptions, beliefs, feelings, attitudes appears to be correlated for both brand equity and customer equity (Tim Ambler & Bhattacharya, 2002). Based on brief examination suggests that brand equity management can be conceptually related to customer equity management.

Several different concepts and approaches have been introduces to the topic of customer equity. A study by Blattberg & Deighton (1996) defined customer equity in terms of optimal balance between what is spent on customer acquisition versus what is spent on customer retention. They calculated customer equity by first measure each customer's expected contribution toward offsetting the company's fixes costs over the expected life time of that customer. Then they discounted the expected contribution to a net present value at the company's target rate of return for marketing investment. Finally they add together the discounted, expected contributions of all current contributions. Other study defined customer equity as the discounted lifetime values of a company's customer base (Rust et al., 2004). According to this study there are three factors that influence customer equity; value equity, brand equity and relationship equity. The definition of brand equity in this study differs from the customer based brand equity definition reviewed on above section which is in this study puts brand equity as the focus on the beneficial differential response to all marketing activities that strong brands produce. Nevertheless based on the study it is revealed that there is a relationship between brand equity and customer equity.

Other concept of Customer equity is based on Customer Lifetime Value (CLV). CLV defined that customer equity is affected by revenue and cost considerations related to customer acquisition, retention, and cross-selling (Leone et al., 2006). CLV have been used as a metric to deciding whether a group of customer is worth acquiring and has value to be managed by the company (Stahl & Heitmann, 2012). There is a simple retention model to calculate CLV. The simple retention model assumes that the customer is acquired, is retained and at some point ceases to be a customer. The retention model driven by retention rates, acquisition rates and profit margin (Stahl & Heitmann, 2012). Retention rates and acquisition rates are common concepts on marketing management thus CLV is the concept of customer equity that can be implemented on day to day marketing management.

### **Relationship of Brand equity and Customer equity**

Many studies have indicated that brand equity is logically a precursor of customer equity which is again emphasis the linkage between brand equity and customer equity (Stahl & Heitmann, 2012). If brand wins the hearts and minds of customers than it is easier to retains/acquires customers. This perspective is supported by the hierarchy of effects model of customer behavior such as AIDA model which posit that customer attitudes are a precursor to consumer actions (Lavidge & Steiner, 1961). Research support the notion that brand equity should link to hard measure of customer equity such as a conceptual model linking brand equity and customer equity (Leone et al., 2006) and using statistical approach analyzes the impact of brand equity to customer acquisition and retention (Stahl & Heitmann, 2012).

Marketing activities such as advertising, price, promotion and new products, drive brand equity and customer equity (Stahl & Heitmann, 2012). Research show how marketing activities are associated with brand equity (Ailawadi et al., 2003). Other research also show how marketing activities are associated with customer equity (Venkatesan & Kumar, 2004). The ultimate function of marketing, in this case is advertising, is to help produce sales. But advertising is cannot be designed to produce immediate purchase on the part of all who are exposed to it. The people who exposed to advertising approach the ultimate purchase through a process or series of steps (Lavidge & Steiner, 1961). Because advertising is not an immediate effect process many methods have been proposed as potential measurement tools of advertising effectiveness, many emphasize the importance of holistic approach to this measurement (Johnstone & Dodd, 2000). Studies evaluating advertising have evolved from simple linear to multivariate models and dynamics demand functions. Linear models that related to product purchase have been the most common approach for describing the relationships between advertising

and actual purchase behavior. Advertising process is viewed as linear and sequential, with models such as AIDA (awareness – interest – desire – action) and ATR (awareness – trial – reinforcement/repurchase) suggesting a hierarchy of effects, where the customer behavior processes through discrete stages of the process (Johnstone & Dodd, 2000). As a conversion model, the AIDA model is concerned with turning non-users into users and pays less attention to post-consumption (post-action) effects. In contrast, ATR incorporates those post-consumption effects. The relationship between both models is depicted in Figure 1.

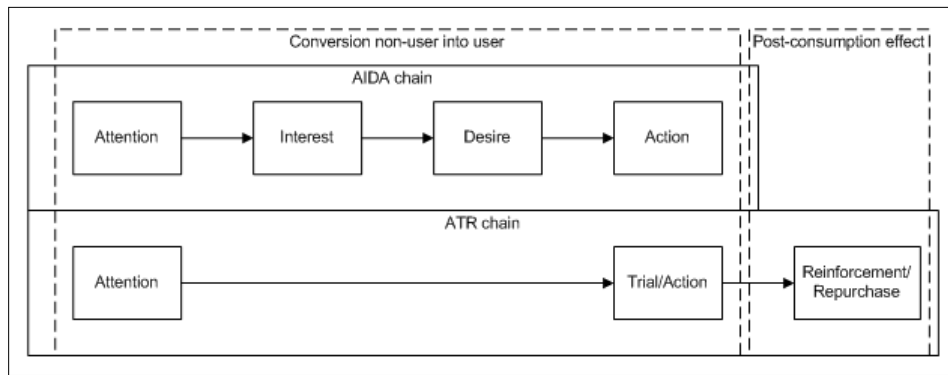

**Figure 1: Relationship between AIDA and ATR**

The earliest and still the best known hierarchical model, AIDA, was reputedly conceived by St. Elmo Lewis in 1098 as a guide to salesmen (Strong, 1925). The AIDA model was developed based on the argument that effective advertising should attract attention, gain interest, create a desire and precipitate action. In other words, if the prospect customer experience attention, interest and desire, the customer will be more likely to act/purchase (Strong, 1925).

Ehrenberg (1974) contended that advertising was not as powerful as its proponents believed and that repeat buying is the main determinant of sales. Therefore, advertising and marketing must focus more on being a reinforcement mechanism in the marketplace rather a persuasive force. He suggests the ATR model, awareness-trial-reinforcement (Ehrenberg, 1974). The ATR model took into account the fact that most buyers were not totally brand loyal and that customers had a “repertoire” of brands from which they purchased fairly regularly (Barry, 1987).

It should also be noted that all of these hierarchy of effects models suggest that sale is the end result of advertising, but many publications emphasize that advertising is not solely responsible for causing sales. Some other marketing activities contributes to the final sale such as the product must be

conveniently available to customers, its package design must be attractive, supported by promotion and must be priced competitively. However to measure advertising effectiveness is the basic measurement of marketing activities effectiveness, which the reason AIDA/ATR model is suitable to conceptualize and operationalize how advertising or marketing works. Thus, toward the years the hierarchy of effects models are used to measure other marketing related areas such as brand awareness, brand feature awareness, brand preference and intention-to-buy. Some of the weaknesses of hierarchy of effect models, AIDA and ATR, are the inability to explain the connection between brand on customer and the models are postulated in non-competitive environment.

### **3. Methodology**

#### **Research strategy**

First the research reviews how brand equity and customer equity have been conceptualized. Then contrast some of the advantages and disadvantages of current conceptualized models and offer a conceptual model as to how those two concepts can be linked through AIDA-ATR customer chain model. A system dynamics model is built based on the findings on literature review and conceptual model. Then system dynamics model simulation and behavior analysis is conducted to find the linkage relation of brand equity on customer equity. Analyses on AIDA-ATR chain on the customer development behavior will explain the relationship of customer equity and brand equity on operationalize perspective. An application study of the model on a capital goods company in Cambodia will not only give additional insights, but also give better understanding on practical purpose related to marketing activities.

#### **System dynamics methodology**

System dynamics methodology is suitable for framing a causal relationship of a dynamics and complex social system within their underlying structures, to get better understanding of the interaction among all elements in the system and to elucidate the general behavior of a given system (Forrester, 1961; Pidd, 2009; Roberts, Andersen, Deal, Garet, & Shaffer, 1983; Sterman, 2000) which is suitable to model brand equity and customer equity. Previous researches suggest that system dynamics methodology is suitable to analyse the concept of brand equity and customer equity. For example Crescitelli & Figueiredo (2009) analyses the evolution of brand equity over time using system dynamics model and simulation. Chan, Ip, & Cho (2010) construct a system dynamics model for predicting the customer equity value from the perspective of marketing strategy. However there is lack of study on using system dynamics approach to link the concept of brand equity on customer equity or to study the causal relationship



between these two concepts. SD methodology also have been exposed to the concept of aging chain, in this case customer chain. Warren (2010) showed the concept of customer choice pipeline on the effect of marketing to customer aging chain using SD.

### Conceptual Model

The literature review suggests the simplified conceptual model to describe the linkage of brand equity and customer equity (see Figure 2). The conceptual model is a modification based on the work of Stahl & Heitmann (2012) on linking brand equity and customer equity.

The model proposes that marketing actions influence both brand equity and customer equity. Brand equity has a direct impact on the customer equity. The model argue that customer mind-set which is represent by brand equity has direct impact to customer equity (Leone et al., 2006) and indirect effect to customer development chain. Customer development chain is represented by the AIDA and ATR chain. AIDA-ATR chain as a model of customer behavior toward purchase used to illustrate the development of customer through their behavior. By doing this, the model provides a different perspective on the concept of brand equity and customer equity. It gives operational insights on the effect of brand equity and customer equity through the development of customer chain. The change of customer equity affects the development of customers which represent by the AIDA and ATR chain. The chain of customers affected by brand equity and customer equity, in other word the more customers reside on this chain affects the value of the brand and customer. Eventually the customers reside on the chain determine the company performances indicators.

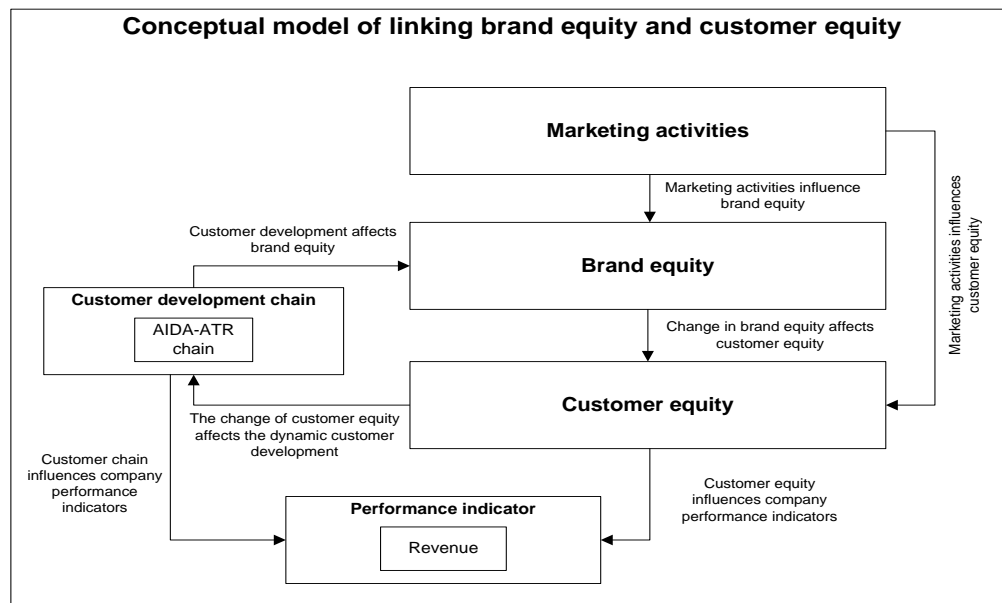

Figure 2: Preliminary conceptual model of brand equity and customer equity relationship

A comprehensive system dynamics model build based on this conceptual model. A simulation and behavior of the system dynamics model will gives insight on the relation of brand equity and customer equity through the customer behavior development on AIDA chain. The general structure and insights from the model will be illustrated by a study of capital good company.

## **4. Dynamic hypothesis**

### **Linking brand equity and customer equity**

The linkage between brand equity and customer equity is conceptualized with customer development chain using the AIDA-ATR chain model (see Figure 3). AIDA chain model represents the behavior of customers toward purchase of a product. On the other hand ATR chain represents the post-purchase behavior, the repurchase behavior. There is overlap between AIDA and ATR chain – hence a possible combination of these chains into one chain model. Both chains have “Attention” behavior as starting point and “Action” behavior on AIDA overlaps with “Trial” behavior on ATR chain. The combination result of these two chain is Attention – Interest – Desire – Action – Repurchase, each behaviors represented by a stock of customer on the customer development chain.

Brand equity is a precursor of customer equity to determine the customer behavior. Aaker's brand equity model has three main components; brand awareness, brand loyalty and perceived quality. Referring to the definition of brand equity as the differential effect of customer knowledge to a brand and as value of having a well-known brand, then brand equity can be illustrated with the change of customer behavior toward a product. The three components of brand equity can be represented on the development of customer chain. Brand equity components have affect in specific stages of customer behavior. Saying a brand that cause change in customers behavior from having attention to product then become interest on the product and finally have desire to purchase is similar to say that a brand has a strong awareness among customers then gains acknowledgement among customers and finally the quality of the brand stimulating customers desire to act (i.e., to buy the product). Having said that, customer behavior from attention stage to interest stage then desire stage can represents the components of Aaker's brand equity model; brand awareness, brand loyalty and perceived quality. Thus numbers of customers reside on attention stage, interest stage and desire stage illustrates the value of brand equity. The change numbers of customers in these three stocks affects the value of brand equity. A positive change of brand equity has a positive impact to customer development chain and vice versa. This mean a positive change of brand equity attracts more new potential customers into the chain thus it increases the numbers of customers reside on attention stage, interest stage and desire stage.

However the model structure does not suggest the operational way on how to measure the value of brand equity from intangible variables. The structure of the model only suggests that the development of customers on attention stage, interest stage and desire stage can illustrates the value of brand equity. To measure the actual value of brand equity it needs additional structures and beyond the scope of this research.

Customer equity as a Dollar value of customer base in terms of future revenues also can be illustrated with customer chain. CLV model of customer equity defined that it has two components; customer acquisition and customer retention. To convert customers who have desire to buy to actually act and buy the product is called customer acquisition. The basic idea of customer retention is to convince current customers to buy again the next time they have a chance. Customer acquisition and retention also parts of customer behavior chain. Both represented by the numbers of customers which reside on the action stage and repurchase stage. Acquisition rate is the rate of converting customers on desire stage to action stage and retention rate is the rate of convincing customers on action stage to repurchase stage. Customers that reside on these stages are the one that generate revenues to the company. Referring back to the idea of customer equity in terms of future revenues, then the numbers of customers on action stage and repurchase stage illustrate the concept of customer equity. The change numbers of customer on these stocks affects the value of customer equity. A positive change increases the value of customer equity and vice versa. An increase of customer equity affects the potential future revenues. The calculation of customer equity in term of future revenues based on this model structure is beyond the scope of this research. However the model argues that customer equity influences brand equity in a way that positive change of brand equity has a positive multiplication affects to new potential customers. It represents the real world scenario that more customers will attract new potential customers through referral or word of mouth. And also more active customers equal to more product population in the market, it increases brand awareness which has positive affect to brand equity.

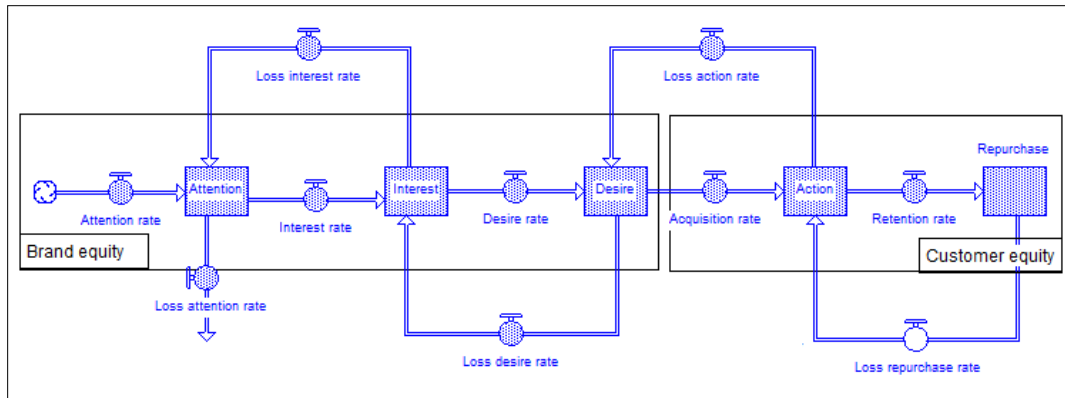

**Figure 3: Linkage between brand equity and customer equity**

### **Change in brand equity and customer equity**

Brand equity and customer equity affected by the marketing activities. The marketing challenge is to move customers through a series of stages on the customer chain until they become buyers of the product. Marketing influences flow rates on the customer chain. These flow rates influence by five categories of marketing spending; (1) marketing to build customers attention; (2) marketing to build customers interest; (3) marketing to motivates customers desire, (4) marketing to acquires customers; and (5) marketing to convinces customer to repurchase the product (see figure 4). Marketing spending changes the conversion rate on each flow. Flow rates determine the accumulation and depletion process of the stock. Marketing spending on each stage is influenced by the amount of marketing budget and the percentage budget spending allocation (see Figure 4). How much money allocated to the desired flow determines the percentage of conversion rate. The more money allocated on particular marketing activities provide higher conversion rate and eventually increases the accumulation process of the stock. For example the more money allocated for marketing to build customers interest on the product, increases the percentage of new interest customers per month and eventually increases numbers of customers in interest stage. For simplification purpose the conversion variables that translate money into customers are left out of the picture.

Not all customers who have interest on a product eventually have desire to buy the product despite all marketing efforts. Some of them are loss interest on the product. This situation is illustrated on the model by loss rate flow from the right stock to the left stock (see figure 4). The loss rate flows, due to simplicity, are in a constant percentage fraction. However in actual operational system, these flows also influence by marketing activities and other variables.

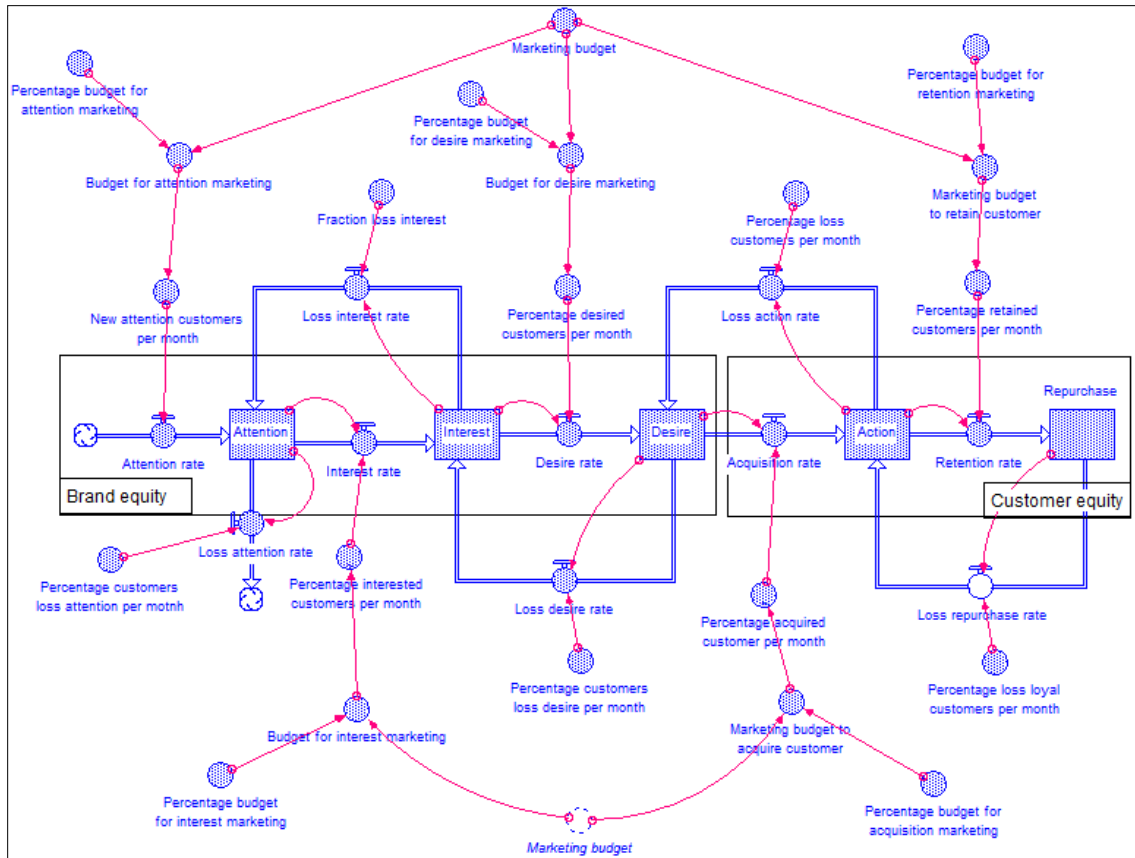

Figure 4: Customer chain and marketing budget

### The effect of brand equity and customer equity to the customer chain

As mention before, brand equity and customer equity have an interactive effect such that marketing actions to improve customer equity can also improve brand equity and vice versa. This interactive effect showed by the “effect of brand equity” and “effect of customer equity” (see Figure 5). It should be noted that “effect of brand equity” and “effect of customer equity” is not based on the actual value of brand equity and customer equity, to measure the actual value of these two equities is beyond the scope of this research. The change of brand equity and customer equity in this model is based on the change of total customers’ numbers that reside on each stock. The structure to calculate the change of these values is left out of the picture for simplification purpose.

The “effect of brand equity” originated from the change of total customers reside on three stocks of brand equity components; (1) attention; (2) interest; and (3) desire. Effect of brand equity influences acquisition flow and eventually changes the value of customer equity (see figure 5). A positive change of brand equity increases acquisition flow rate and vice versa. It has a positive multiplication

effect to acquisition rate and increases numbers of customers who converted from desire stage to action stage. Acquisition rate is an outflow rate on desire stage thus; with the increase of acquisition rate the outflow rate from customers on desire stage also increases and, it reduce the numbers of potential customers that can be convert into action stage. Brand equity also influences the attention flow rate, a positive change of brand equity will increase the attention flow rate and vice versa (see figure 5).

The “effect of customer equity” originated from the change of total customers’ numbers reside on two stocks of customer equity components; (1) action; and (2) repurchase. Customer equity gives effect to attention rate; a positive change on customer equity gives positive effect to attention rate and vice versa (see figure 5). These two effects showed the interactive effect of brand equity and customer equity to the customer development chain.

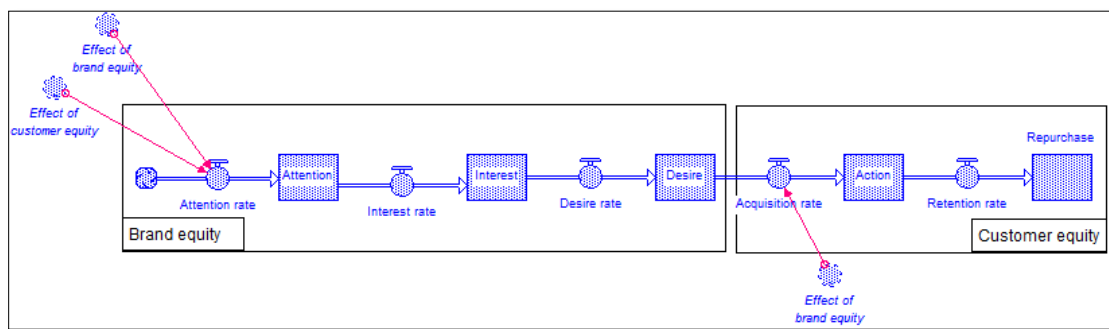

**Figure 5: Effect of brand equity and customer equity**

### Revenue as performance indicator

This model used accumulation of revenue as company performance indicator. The stock of revenue is influence by the revenue rate. Revenue rate is based on how many customers reside on customer equity section which is the total of “action customer” and “repurchase customer”. Multiplication of the total customer with price of product and average quantity bought per customer gives the amount of revenue per month (see Figure 6).

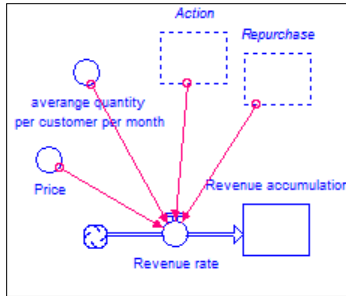

Figure 6: Revenue accumulation

**Feedback loops on the model**

The diagram in Figure 7 represents the feedback loops structure of brand equity and customer equity in the model. Generally the model structure has a lot of feedback loops if we consider all small feedback loops that involve in each stock on customer chain. However, there are three main active loops on the model to represent the linkage of brand equity and customer equity also the interaction between both of them in the model. Brand equity involves in reinforcing loop and balancing loop in the model. Customer equity involves in reinforcing loops toward new attention rate.

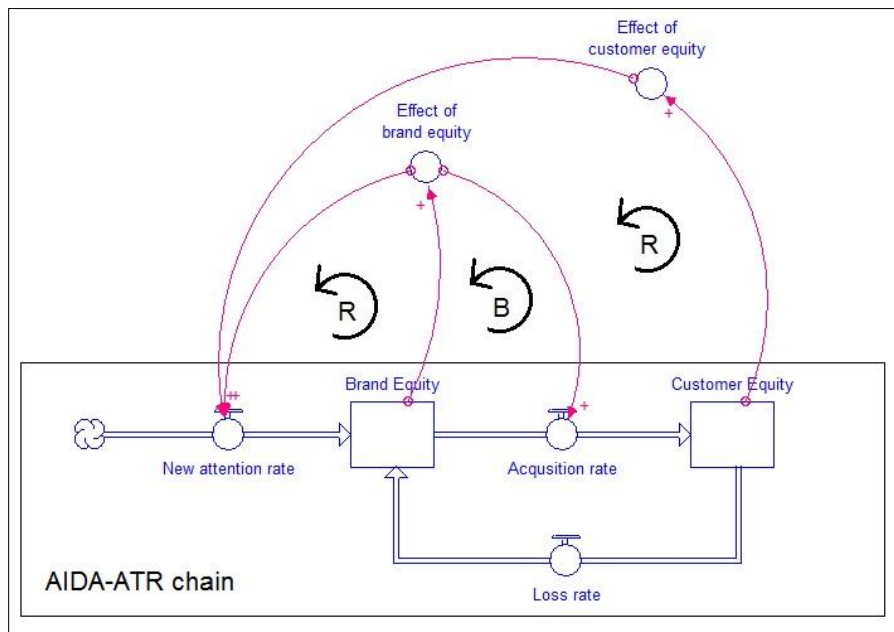
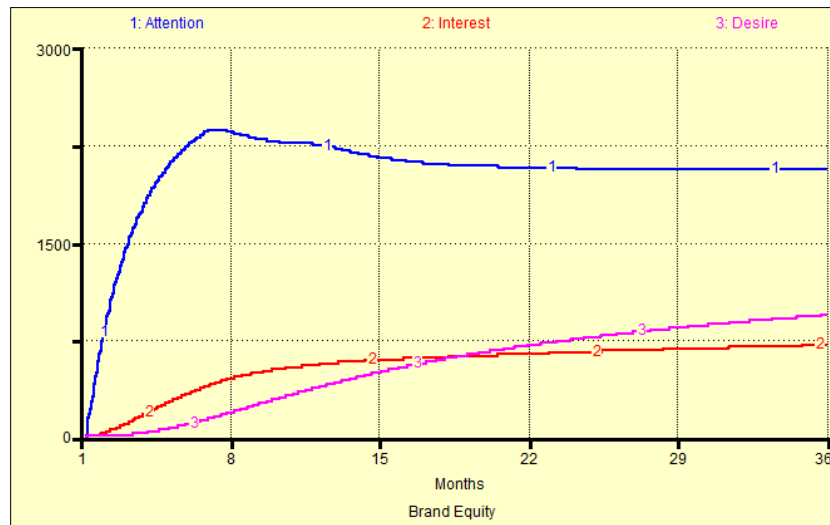

Figure 7: Feedback loops diagram

## 5. Model behavior

### Model behavior baseline

Two variables that important to determine the behavior of the model are marketing budget and percentage marketing budget allocation to each flow. To determine the baseline of model behavior, the simulation on based on the following input: Marketing budget is \$100,000 and constant percentage of budget allocation which is 20% of the marketing budget. The following graphs depict the model's baseline behavior.



Graph 1: Brand Equity baseline behavior

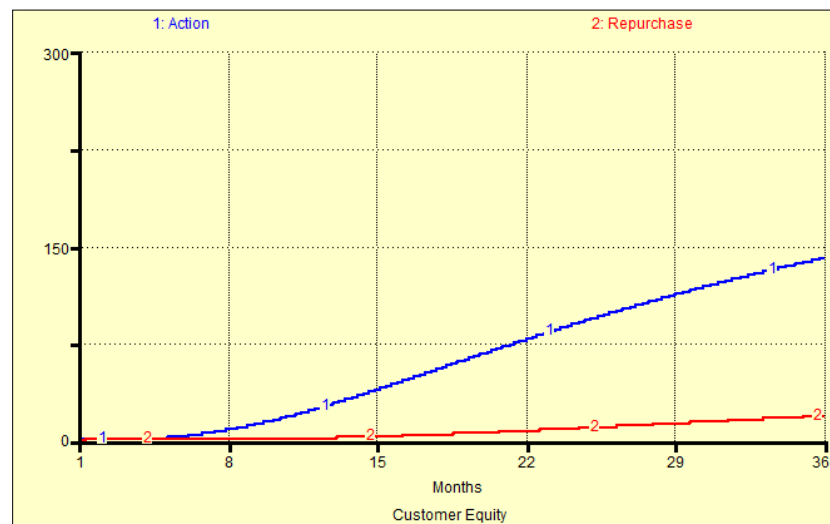

Graph 2: Customer Equity baseline behavior



### Model behavior with different percentage marketing budget allocation

Percentage marketing budget allocation is the key variable to determine the flow and accumulation of customer development chain. Marketing management often has to split the marketing budget to certain marketing programs in order to reach the desire objectives. Marketing budget can be different between marketing program to attract new potential customers and marketing program to retain current customer. The same amount of budget will not produce the same result for different marketing programs. It is logical to argue for a new company to emphasis their marketing budget to get attention from potential customer. Once they have enough potential customers, they shift their marketing budget to converts them into their actual customers. In order to illustrate it, the model is tested with different kind scenarios of marketing budget allocation.

Table 1 summarizes the percentage marketing budget on each flow:

Flow rate	Time step				
	0-6	6-12	12-18	18-24	24-36
Attention flow rate	30%	20%	10%	20%	20%
Interest flow rate	20%	30%	20%	10%	20%
Desire flow rate	10%	30%	20%	20%	20%
Action flow rate	20%	10%	30%	20%	20%
Repurchase flow rate	20%	10%	20%	30%	20%

**Table 1: Summary of marketing spending**

The following graphs are the results of the model behavior using above table value.

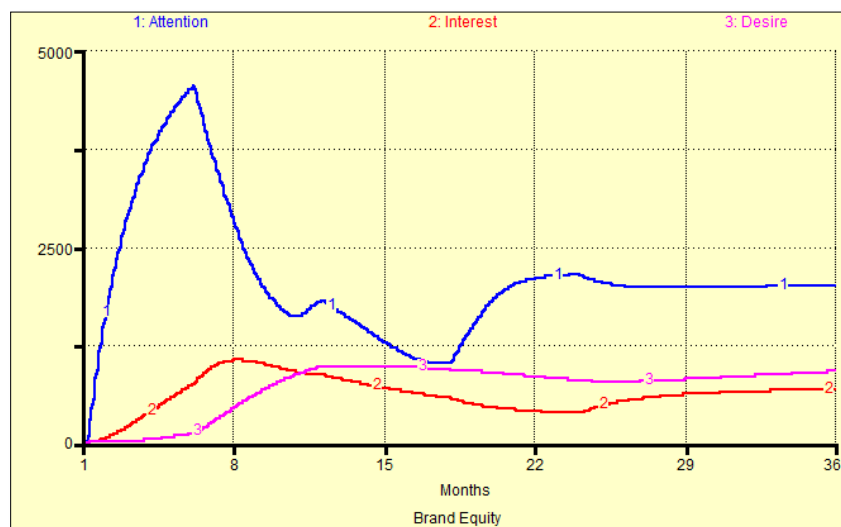

**Graph 3: Brand equity with different marketing budget allocation**

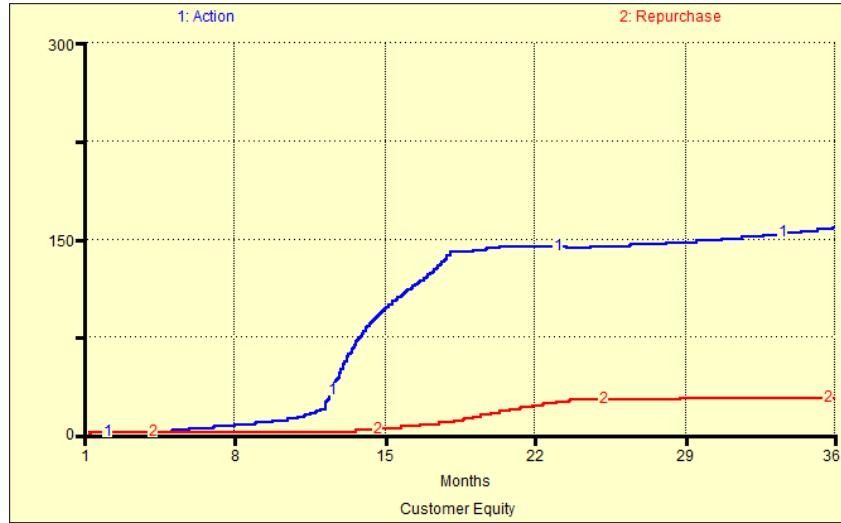

**Graph 4: Customer equity with different marketing budget allocation**

## 6. Finding and Discussion

Graph 5 shows a customer development chain for 36 months simulation with an equal (i.e., 20%) marketing budget allocation on each flow. The baseline case, the budget is allocated evenly, so \$20,000 is spent on each five marketing activities each month. It takes a long time for marketing at the front end of the chain to bring potential customers and for them to actually buy the product and become action customers. The baseline behavior shows a high increase in numbers of customers on the attention stage at the very beginning (see graph 1). The development of customers on the interest and desire stages is not as rapid as on the attention stage. This is because the interest customer rate and the desire customer rate stay constant; thus, the high accumulation of customers in the attention stage is not quickly converted into subsequent stages. Customers on interest stage and customer on desire show a slow development at the beginning due to time delay to accumulate. At the beginning, there is a significant change of total customers' numbers on brand equity component. Later time step (see graph 1), approximately after 7 months, there are significant amount of customers reside on interest stage and desire stage; thus, the change of total customers' numbers on brand equity component start to decrease and eventually decrease brand equity. A decrease brand equity gives a negative effect to new attention rate thus, this reinforcing loops works on negative manner and slows down the growth of customer on attention stage. Approximately after 15 month, numbers of customers on attention rate starts to stabilize because there is no significant impact from brand equity to new attention rate (see graph 1).

A constant 20% on each marketing budget enables to get new actual customer, action customer, after approximately five months (see graph 2). With this type of marketing investment the company gets their first loyal customer, repurchase customer, after ten months (see graph 2). This shows that, if a new company who starts with zero customers, it needs time for them to develop their customer base. Graph 5 shows a realistic customer development from operational point a view for a company start with zero customers. The company needs time to develop potential customer base, the time delay to develop potential customer prolong the time for company to acquire their actual customer, action customers. Since the brand equity and customer equity depend on the numbers of customer on the customer chain. A slow development on particular or the whole component on customer chain affects brand equity and customer equity. Change of brand equity and customer equity impact the multiplication factor to certain flow rate (see figure 5). Graph 1 shows that the development of customer after 8 months has a significant positive effect to brand equity; thus, it gives a positive impact to attention rate and growth the numbers of customer on attention rate significantly after 8 months (see graph 2). The two important components of customer equity are acquisition and retention, therefore a positive effect of brand equity increases total numbers of potential customer lead to increases numbers of acquisition and retention (see graph 5) which mean increases customer equity.

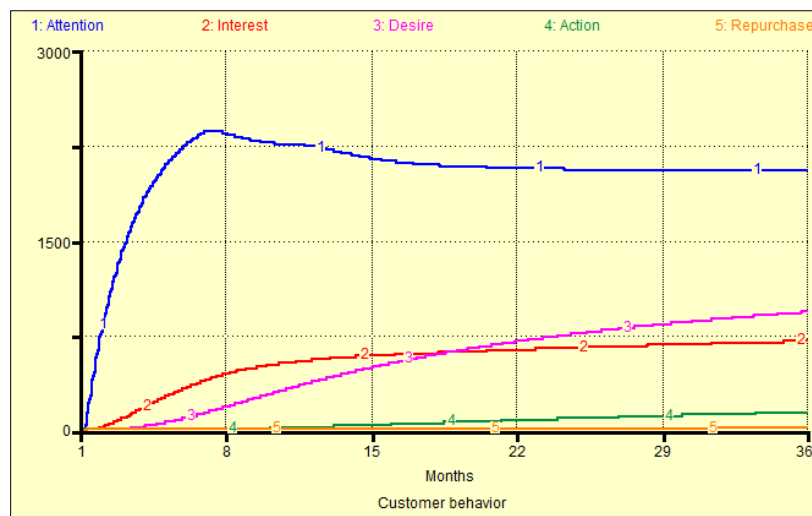

**Graph 5: Customer behavior: baseline**

Graph 5 shows the interactive relationship between brand equity and customer equity. On marketing management, it is important to know the effect of brand equity and customer to the customer base. Although it not generally a bad idea to have a particular amount of customers on certain

stage higher than the other thus, a particular equity grows faster than the other. Depends on the nature of the business, some businesses are easier to attract new interest customers but harder to convert them into action customers; thus, they prefer to focus on their effort on build up their customer equity than brand equity.

The baseline behavior (see figure 5) shows that there is lack of marketing effort to convert potential customers into active customers. This is shown by the high gap between customers on the desire stage and customers on the action stage. Presumably, marketing budget allocation can help the growth of active customers. The baseline behavior shows the difficulty to acquire and retain customer. Even there is a significant increase of customers on action stage, there still a little development of customer on repurchase stage. This scenario illustrates that within a constant percentage marketing allocation to build up customer base, it not produces the same significant result on all customer stages.

The baseline case shows that to build up a faster potential customers and shorter time delay to acquire new actual customer, a certain customer stages are more important to be develops higher than the others. Pre-purchase stages are important in the beginning. Marketing expenses may be quite high in order to bring customers to those stages before converts them into buying the product. There is also a high fraction of customers on these stages that not continue to further stages. A high investment is needed to build customers attention, however sometimes high fraction of these customers eventually simply loss interest on the product. Therefore a quick action to convert customers on attention stages to further stages is very important, and this means to allocate more money on these stages and make less investment on other customer stages.

Graph 6 shows a simulation behavior with different marketing strategies. Marketing activities to build up attention is prioritized first on the first 6 months, followed by marketing to build up interest on the following 6 months. This marketing strategy builds up faster customers on desire stage, so when the following year marketing strategy switches to focus on acquiring customer, it is more effective to acquire more customer compare to baseline case. Marketing budget allocation for attention, interest and desire customers can be cut since the company already builds up a high amount of potential customers. With this type of marketing investment, the company build better customer base within the first 10 months. Comparing the baseline behavior with simulation results produced by using different marketing budget allocation gives clearer insight on how the customer development chain operates. By assigning different marketing allocation budget, the model provides a better illustration from a marketing operational perspective.

Detail marketing strategy case is the following. In the first six months, 30% of marketing budget are allocated to the attention rate and only 10% to the desire rate. The result shows that the development of customers in the attention stage is even higher than compared to baseline behavior. After concentrating on developing high numbers of potential customers in the attention stage, in months 6 to 12, the marketing budget allocation is shifted to increase the conversion of customer into the interest and desire stages. 30% of marketing budget is allocated to interest rate (later to the desire rate), compensated by a lower budget in the attention rate and the action rate. This policy results in a higher increase of customers in the interest and the desire stages compared to baseline behavior. Knowing that there are a lot of customers in the desire stage which have a high potential to be converted into active customers, in months 12 to 18, 30% of the marketing budget is allocated to the acquisition rate to increase the conversion rate from the desire stage to the action stage. The result is a high increase of customers in the action stage, this number of customer is much higher than the one produced by the baseline policy. Allocating money in phased approach provides quicker results regarding acquiring new customers. The baseline behavior takes five months to acquire new active customers, on the other hand with this marketing strategy it only takes four months.

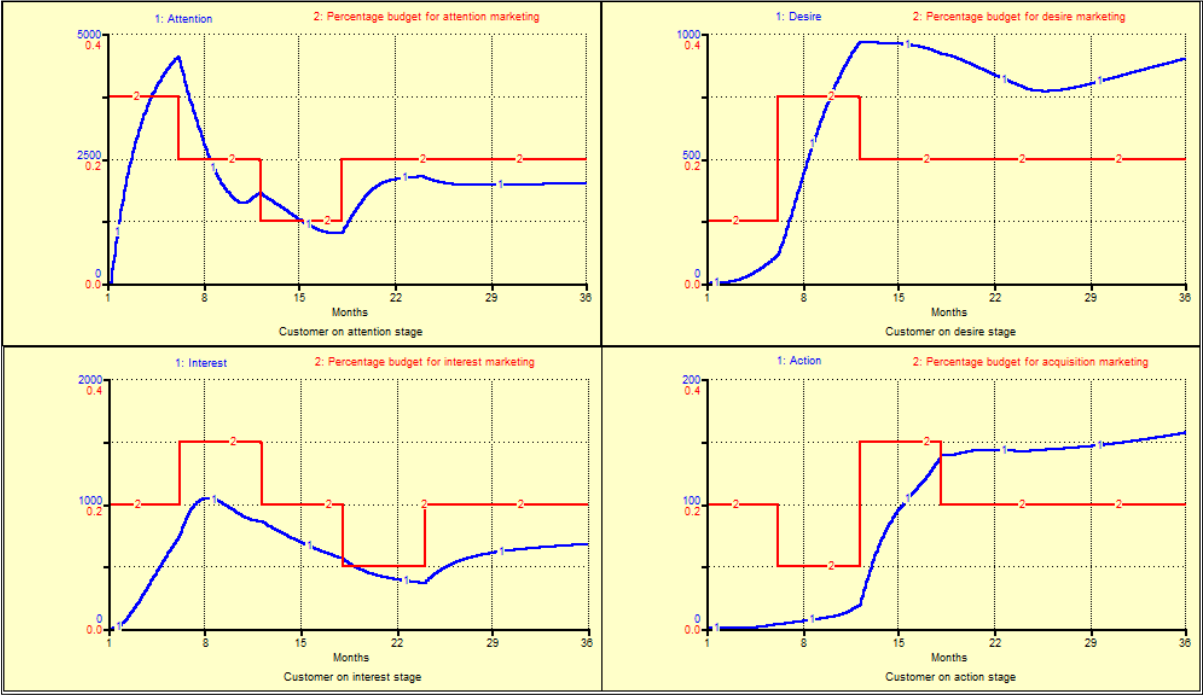

Graph 6: Customer behavior with marketing strategy

The significant difference between the baseline behavior and the phased policy is not only due to investing more money. The effect of brand equity and customer equity to customer chain also takes part on this matter. The feedback from customer chain to each effect determines the multiplication value to attention rate and acquisition rate. The model used a general assumption on each effect graphical function, nevertheless it gives insight on how brand equity and customer equity interaction in the system. The higher change of total customer on brand equity chain gives higher multiplication factor to attention rate and acquisition rate.

Graph 7 shows there is a significant different result of revenue accumulation between baseline behavior and the phased approach. Using a marketing policy that focuses on particular stage of the customer chain gives better result than the baseline strategy. It produces faster revenue compared to the baseline and results in significantly higher revenue.

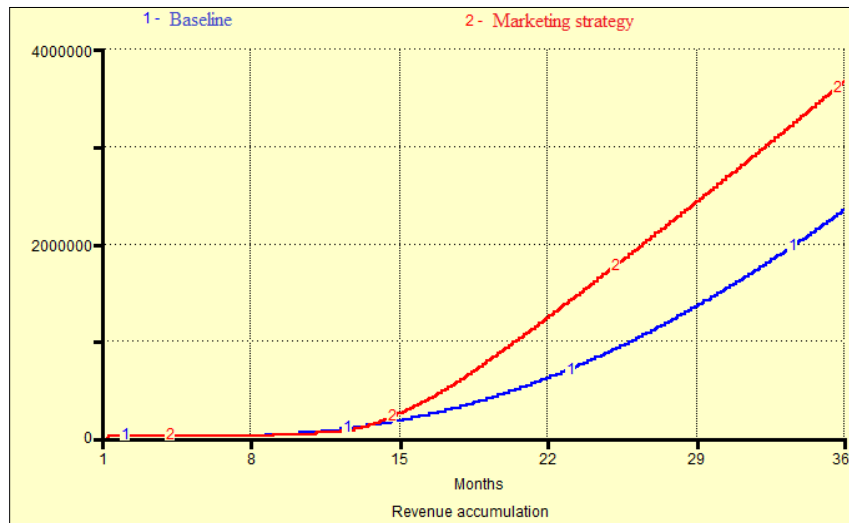

**Graph 7: Revenue accumulation**

## 7. Conclusion

This paper sets the groundwork to conceptualize the linkage between brand equity and customer equity from a system dynamics perspective. The research attempts to produce a working model of linking brand equity and customer equity that could be used to supplant current conceptual models in academia, consultancy and marketing management. The general findings of the current working model give important insights on how marketing strategy can develop brand equity and customer equity, the interaction between brand equity and customer equity, and also how these two equities affect business performance. There is a need to test the behavior of the model with a real case study and validate the

outcomes. However, this paper has attempted to capture the “big picture” of the overall process and it is hoped that future refinement of the model will produce further results.

## 8. Bibliography

Aaker, D. A. (1995). *Building Strong Brands* (p. 400). Simon and Schuster.

Ailawadi, K., Lehmann, D., & Neslin, S. (2003). Revenue premium as an outcome measure of brand equity. *Journal of Marketing*, 1–18.

Ambler, T., & Bhattacharya, C. (2002). Relating brand and customer perspectives on marketing management. *Journal of Service Research*.

Ambler, T., Bhattacharya, C. B., Edell, J., Keller, K. L., Lemon, K. N., & Mittal, V. (2002). Relating Brand and Customer Perspectives on Marketing Management. *Journal of Service Research*, 5(1), 13–25.

Barry, T. (1987). The development of the hierarchy of effects: An historical perspective. *Current Issues and Research in Advertising*.

Blattberg, R., & Deighton, J. (1996). Manage marketing by the customer equity test. *Harvard Business Review*.

Chan, S. L., Ip, W. H., & Cho, V. (2010). A model for predicting customer value from perspectives of product attractiveness and marketing strategy. *Expert Systems with Applications*, 37(2), 1207–1215.

Crescitelli, E., & Figueiredo, J. (2009). Brand equity evolution: a system dynamics model. *BAR-Brazilian Administration Review*, (June), 101–117.

Ehrenberg, A. (1974). Repetitive advertising and the consumer. *Journal of Advertising Research*.

Forrester, J. W. (1961). *Industrial Dynamics*. MIT press.

Gupta, S., Lehmann, D., & Stuart, J. (2004). Valuing customers. *Journal of Marketing Research*, (September).

- Johnstone, E., & Dodd, C. a. (2000). Placements as mediators of brand salience within a UK cinema audience. *Journal of Marketing Communications*, 6(3), 141–158.
- Keiningham, T. (2005). The brand-customer connection. *Marketing Management*, (August), 33–38.
- Keller, K. L. (2003). *Strategic Brand Management: Building, Measuring, and Managing Brand Equity*. Pearson Prentice Hall.
- Lavidge, R. J., & Steiner, G. a. (1961). A Model for Predictive Measurements of Advertising Effectiveness. *Journal of Marketing*, 25(6), 59.
- Leone, R., Rao, V., & Keller, K. (2006). Linking brand equity to customer equity. *JOURNAL OF SERVICE RESEARCH*, 9(2), 125–138.
- Pidd, M. (2009). *Tools for Thinking: Modelling in Management Science* (p. 304). Wiley; 3 edition.
- Roberts, N., Andersen, D. F., Deal, R. M., Garet, M. S., & Shaffer, W. A. (1983). Introduction to computer simulation: the system dynamics approach.
- Rust, R., Lemon, K., & Zeithaml, V. (2004). Return on marketing: using customer equity to focus marketing strategy. *Journal of Marketing*, 68, 109–127.
- Stahl, F., & Heitmann, M. (2012). The impact of brand equity on customer acquisition, retention, and profit margin. *Journal of Marketing*, 76(July), 44–63.
- Sterman, J. (2000). *Business Dynamics: Systems Thinking and Modeling for a Complex World* (p. 1008). McGraw-Hill/Irwin.
- Strong, E. K. (1925). Theories of selling. *Journal of Applied Psychology*, 75–86.
- Venkatesan, R., & Kumar, V. (2004). A customer lifetime value framework for customer selection and resource allocation strategy. *Journal of Marketing*, (October).
- Warren, K. (2010). *Strategy Dynamics Essentials*. Strategy Dynamics Limited.