

A Matrix Architecture for Development of System Dynamics Models

James R. Burns
Jerry S. Rawls College of Business Administration
Texas Tech University
Lubbock, Texas 79409
(806) 742-1547
jimburns@ttu.edu

Onur Ulgen
Industrial, Manufacturing and Systems Engineering Department
University of Michigan—Dearborn
4901 Evergreen
Dearborn, Michigan 48128
ulgen@umich.edu

Abstract--A matrix architecture for development of system dynamics models is described. The approach concentrates on the formulation of the Forrester stock and flow diagram, and incorporates the concept of an interaction matrix to assist in the formulation of such models. The interaction matrix is formally derived. Set and graph-theoretic concepts are utilized in the derivation. The rules (primitives) of system dynamics are expressed in the form of definitions and axioms. From these primitives, theorems are proven. The theorems describe whether interaction between certain pairs of quantity types is possible and what type of interaction can exist between the pairs. The theorems are used to rationalize the interaction matrix. The paper is accompanied by a companion article [3] by the same authors that employs the interaction matrix in a component development strategy. The methodology is applied to example problems in the companion paper.

Notation, assumptions, definitions, and axioms

In this article the assumptions and axioms of system dynamics will be asserted using set and graph theory. In addition, notation and definitions will be introduced as required by the component approach. Using these primitives, theorems that describe what interactions are possible are proven. The implications for the interaction matrix are then illustrated.

Notation

Let the model M by which a system is to be represented consist of the following assemblage: $M = \{B, X, C_x\}$ where B is the boundary of the system, X is the set of components used to represent the system and C_x is the set of connectors that exist among the components. A *component* is a subsystem of a system that is differentiated (from other subsystems) by the type of flow contained within it. Each component will be allowed to contain only a single type of flow, although that flow could proceed through several stocks.

All stock or level variables that accumulate a particular flow are members of the same component. All rates whose associated units are simply the unit of the flow divided by time are also members of the same component. Thus a component is a subsystem of the larger system encompassing all rates and stocks associated with a particular flow.

Another assemblage which could be used to represent systems is the following: $M = \{B, Q, C\}$, where C is the set of connectors among the set of quantities Q , and B is the boundary of the system. The boundary B of the system is the same under both definitions and is specified once the quantities have been chosen.

The set Q shall also be referred to as a space because the quantities represented may be variables that are functions of time. Let q be the vector of quantities contained in the set Q . An element of q will be denoted by a q_i . A system that can be represented by \tilde{n} quantities will possess a q vector of length \tilde{n} , whose associated quantity space Q is of dimension \tilde{n} . When the vector $q(t)$ is an element of Q , this is denoted by $q \in Q$.

Using system dynamics methodology, i.e. Forrester [5,6,7,8], the sets Q and C are partitionable into the following subsets: $\Pi_Q = \{S; O; U; V; P; R\}$ and $\Pi_C = \{F; I\}$. This partitionability follows directly from the fact that each of the elements in Q and C can be uniquely identified and therefore will belong to one and only one of the respective subsets of Q and C .

The above quantity categories are listed in Figure. 1 with their respective set and symbolic representations. This s is the vector of stock variables whose associated space is S , an individual element of which is denoted by s_i and similarly for the other quantity categories. The space S can also be thought of as the subset of quantities q_i that are stocks. To designate a particular quantity q_i as a stock, the notation $q_i \in S$, meaning q_i is an element of the set S , is used. If a quantity q_i is known to be a member of one or two quantity types, say the set of parameters P or inputs U , this is denoted by $q_i \in PU$. Thus, PU denotes the union of P with U : $PU = P \cup U$.



<u>Name</u>	<u>Subset Member</u>	<u>Symbol</u>
Stock (level) variable	$s \in S$	
Output variable	$o \in O$	
Input variable	$u \in U$	
Auxiliary variable	$v \in V$	
Parameter (constant)	$p \in P$	
Rate variable	$r \in R$	
Flow connector	$c_{ij} \in F$	$i \longrightarrow j$
Information connector	$c_{ij} \in I$	$i \dashrightarrow j$

Figure 1. Subset and symbolic presentations of quantity and connector categories.

$$\begin{array}{c}
 1 \\
 2 \\
 3 \\
 4 \\
 5 \\
 6 \\
 7
 \end{array}
 \begin{array}{c}
 \left[\begin{array}{ccccccc}
 1 & 2 & 3 & 4 & 5 & 6 & 7 \\
 0 & 1 & 0 & 0 & 0 & 0 & 0 \\
 0 & 0 & 1 & 0 & 0 & 0 & 0 \\
 0 & 1 & 0 & 1 & 0 & 0 & 0 \\
 0 & 0 & 0 & 0 & -1 & 0 & 0 \\
 0 & 1 & 0 & 0 & 0 & 0 & 1 \\
 0 & 0 & 0 & 1 & 0 & 0 & 0 \\
 0 & 0 & 0 & 0 & 0 & 0 & 0
 \end{array} \right]
 \end{array}$$

Square ternary matrix (STM)

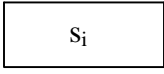
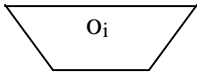
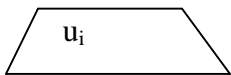

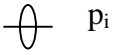
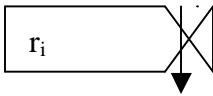
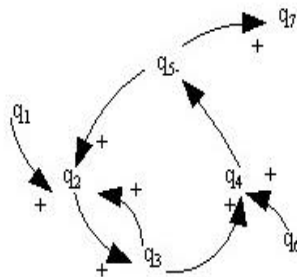
Causal loop diagram (CLD)

		1	2	3	4	5	6	7
P	1	0	I	0	0	0	0	0
R	2	0	0	F	0	0	0	0
S	3	0	I	0	I	0	0	0
R	4	0	0	0	0	-F	0	0
S	5	0	I	0	0	0	0	I
P	6	0	I	0	I	0	0	0
O	7	0	0	0	0	0	0	0

Modified square ternary matrix (MSTM)

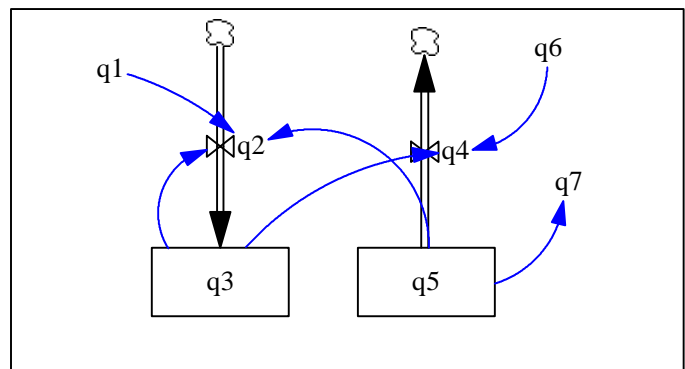

Stock-and-Flow Diagram (SFD)

Figure 2. An Isomorphic Correspondence of the STM to the CLD and of the MSTM to the SFD of a Hypothetical System.

A connector directed from q_i toward q_j will be represented by c_{ij} or (q_i, q_j) . Each of the connectors are signed and may be used to represent either a transmission of information or a transfer of substance (a flow). In general, a connector is said to exist if q_i somehow directly affects, causes, influences, or has an impact upon q_j . The set C of all connectors c_{ij} is defined by causal relations \mathfrak{R} on $Q \times Q$ and can be formatted for computer manipulation in the form of a square ternary matrix. An example of a square ternary matrix and its associated causal diagram are provided in Fig. 2.

The capability to represent symbolically the connectors and quantities adjacent to or associated with a quantity q_j is needed in the following development. Let $A_c(q_j)$ represent the set of signed connectors directed toward q_j , and let $E_c(q_j)$ represent the set of signed connectors directed away from q_j . Similarly, let $A_q(q_j)$ represent the set of quantities which have connectors directed toward q_j and therefore are adjacent to q_j , and let $E_q(q_j)$ represent the set of quantities which have connectors directed away from q_j and therefore are adjacent to q_j . The sets $A_c(q_j)$, $A_q(q_j)$ will be referred to as the affector subsets of q_j , whereas the sets $E_c(q_j)$ will be referred to as the effector subsets of q_j .

In the ensuing discussion, set operators are used to denote the union, intersection, and subsets of sets, using the symbols \cup , \cap , and \subseteq , respectively, whereas logical operators are used to denote the ‘and’, ‘or’, and ‘not’ operations between propositions, using the symbols \wedge and \vee , respectively. The notation $A_c(q_j) \bar{I}$, for example, denotes the proposition, considered to be true, that $A_c(q_j)$ is a subset of the set I . When its occurrence is simultaneous with the proposition $E_c(q_j) \bar{I}$, the compound proposition is denoted $A_c(q_j) \bar{I} \wedge E_c(q_j) \bar{I}$. Using the suggested notation the assumptions can be stated in the next section.

Finally, X_i will be used to denote component I , and quantities within X_i will be denoted by Q_i . Specifically, the set of rates within X_i will be denoted by R_i while the set of stocks within X_i is S_i . Similar conventions apply to the remaining quantity types: auxiliaries, outputs, inputs, and parameters. On the other hand, quantities that appear at the interface between two or more components will be denoted by Q_b and similarly for the specific quantity types: V_b, P_b, U_b, O_b . As previously noted, by the definition of component, between-component quantities cannot include those quantities that control and accumulate flows, i.e. rates and stocks. All flows must occur within a component and wherever a flow is observed, a component must be defined for it.

Assumptions

As has been observed, the component approach assists with the generation and identification of each quantity and connector. However, a minimal understanding of the quantity and connector types employed in system dynamics is assumed on the part of users. Moreover, the approach assumes that once a Forrester schematic or stock-and-flow diagram has been arrived at, there is an inherent behavior or set of behaviors that is prescribed by the diagram; the purpose of the simulation process is to extract that behavior or set of behaviors.

The following additional assumptions are made by the approach being described:

- (1) The insertion of integrating functions (delays, smoothing functions in information channels) will be performed after the delineation of the preliminary schematic (stock-and-flow) diagram of the system.
- (2) Information paths leading from rates to auxiliaries, outputs or other rates will be omitted completely. The same information used by the rate will be directly channeled to the quantity under consideration, where the rate value can be reconstructed. This eliminates the need for an information path leading from a rate to any other quantity in system dynamics.

Under such conditions all connectors directed toward a particular quantity of the same type, either F or I , and similarly for connectors directed away from a particular quantity. For example, all connectors directed both toward and away from an auxiliary are information connectors because of the nature of auxiliaries. In a similar vein all connectors directed toward a stock are flow connectors; all connectors directed away from a parameter or an input and all connectors directed toward outputs are information connectors when these quantities are considered within the context of the CLD.

It is very infrequent that a mixture of inward-directed or outward-directed connectors is observed. However, such mixtures could occur on the input side of a level and on the output side of a rate as previously intimated by assumptions (1) and (2) above. These mixtures will be momentarily neglected in favor of the elegant simplicity that results from such benign neglect. This we state as proposition S1, the continuity proposition.

S1. *Continuity.* For any q_j .

$$[A_c(q_j) \cap I = \{ \hat{0} \vee A_c(q_j) \}] \wedge A_c(q_j) \cap F = [A_c(q_j) \vee \hat{0}]$$

Also,

$$[E_c(q_j) \cap I = \{ \hat{0} \vee E_c(q_j) \}] \wedge E_c(q_j) \cap F = [E_c(q_j) \vee \hat{0}]$$

Here, $\hat{0}$ denotes the null set. In words, the proposition asserts that the members of the connector subset $A_c(q_j)$ are all of the same connector category, either I or F , and that the members of the connector subset $E_c(q_j)$ are likewise all of the same connector category, either I or F , and that this is true for all q_j . The reader can empirically verify that the models described in Goodman [10] are compatible with this proposition once integrating functions in information channels and information paths leading from rates to outputs are removed and these models are considered in their causal loop diagram formats.

The insertion of integrating functions in information or flow channels is accomplished in step 8 of the component approach as discussed in the companion paper [3]. If the user desires, it would also be possible to insert information links from rates to outputs; however, as previously discussed these links are not necessary because the modeler can always reconstruct the rate using the information directed toward it at another quantity.

Using the continuity proposition it is now possible to state precise set-theoretic definitions for each of the quantity types in terms of the connectors adjacent to them.

Definitions

Provided in what follows are set-theoretic definitions of the quantity and connector types of system dynamics, analogous definitions in numerous contexts can also be found in Forrester [5, 6, 7, 8].

Parameters, inputs, and outputs are defined first.

D1. *Parameters and inputs.* Any quantity q_j whose associated $A_c(q_j) = \hat{0}$, the null set, and $E_c(q_j) \subseteq I$, is a parameter or an input; that is, $A_c(q_j) = \hat{0} \wedge E_c(q_j) \subseteq I \Rightarrow q_j \in \text{PU}$.

Note that parameters are distinguished from inputs by virtue of an identified manager's capability to manipulate or change the latter. In terms of the STM, whereas $A_c(q_j) = \hat{0}$, then q_j is affected by nothing and its associated column, column j , is filled with zeros. In Fig. 2, quantities q_1 and q_6 are members of the input-parameter subset because their columns consist entirely of zeros and their respective $E_c(q_j)$ are subsets of I .

D2. *Outputs.* Any quantity q_j whose associated $E_c(q_j) = \hat{0}$, and $A_c(q_j) \subseteq I$, is an output; that is $E_c(q_j) = \hat{0} \wedge A_c(q_j) \subseteq I \Rightarrow q_j \in \text{O}$. In terms of the STM, whenever $E_c(q_j) = \hat{0}$, then q_j affects nothing and its associated row, row j , is filled with zeros. In Fig. 2, quantity q_7 is potentially a member of the set of outputs provided its associated inward-directed connector c_{57} ($=A_c(q_7)$) is an information connector.

In system dynamics, stocks can be recognized as accumulations or integrations of rates of flow. They integrate the results of action in a system. The following definition for stocks is intended to permit recognition of the same on the basis of the kind of connectors directed toward, and directed away from the stock.

D3. *Stocks.* Any quantity q_j whose $A_c(q_j) \subseteq F$ and whose $E_c(q_j) \subseteq I$ is a stock; this we write as follows:

$$A_c(q_j) \subseteq F \wedge E_c(q_j) \subseteq I \Rightarrow q_j \in S$$

In words, this definition asserts that any quantity whose affector subset A_c is a subset of the set of flow connectors and whose effector subset E_c is a subset of the set of information connectors is a stock. Suppose that all interactions along row 3 in Fig. 2 were identified as information links whereas all interactions indicated in column 3 were known to be flows. The q_3 would be classified as a stock. This definition is consistent with the notion that information generally proceeds from stocks to rates, whereas rates control the flows into and out of stocks. The next definition is for rates.

D4. *Rates.* Any quantity q_j whose $A_c(q_j) \subseteq I$ and whose $E_c(q_j) \subseteq F$ is a rate; thus,

$$A_c(q_j) \subseteq I \wedge E_c(q_j) \subseteq F \Rightarrow q_j \in R$$

This definition asserts that any quantity whose inward-directed connectors A_c are information connectors and whose outward-directed connectors E_c are flow connectors is a rate. Referring to

Fig. 2, if c_{45} was an identified flow connector whereas c_{34} and c_{64} were known to be information links, then q_4 must by D4 be a rate.

Auxiliaries are those quantities placed within information paths that modify or transform the information as it is passed from stocks to rates. The following definition is given for auxiliaries.

D5. *Auxiliaires.* Any quantity q_j whose $A_c(q_j) \subseteq I$ and whose $E_c(q_j) \subseteq I$ is an auxiliary; thus,

$$A_c(q_j) \subseteq I \wedge E_c(q_j) \subseteq I \Rightarrow q_j \in V$$

Flow connectors generally indicate that substance is being moved from place to place within a system, such substance being controlled by rates. On the other hand, information connectors do not cause a transfer of substance within a system but just give information about the magnitude of the content. The following definitions are given for flow and information connectors.

D6. *Flow connectors.* Any connector $c_{ij} = (q_i, q_j)$ whose q_i is a rate or whose q_j is a stock, is a flow connector; mathematically, this is written $q_i \in R \vee q_j \in S \Rightarrow c_{ij} \in F$.

D7. *Information connectors.* Any connector $c_{ij} = (q_i, q_j)$ whose q_i is not a rate and whose q_j is not a stock is an information connector; thus $q_i \in V \cup S \cup P \cup U \wedge q_j \in V \cup R \cup O \Rightarrow c_{ij} \in I$.

In what follows, use is made of the causal relation alluded to in Klir [13]. Klir suggests that causal relations exist whenever the dependent quantities can be expressed *explicitly* and uniquely as a function of the independent quantities. A binary causal relation $\mathfrak{R}(\cdot, \cdot)$ disallows (by definition) the following formulations:

- (1) self-loops involving a single quantity;
- (2) loops involving exclusively information paths or auxiliary variables;
- (3) more than one connector joining any two quantities (q_i, q_j) ; and
- (4) connectors that have more than one originating quantity q_i or more than one destination quantity q_j .

Coincidentally, none of the above constructions are allowed in system dynamics methodology; consequently, all legitimate relations in system dynamics are causal relations. Since self-loops are not allowed, $\mathfrak{R}(q_i, q_i) = \hat{0}$ for all (i) and all individual entries along the diagonal in the interaction matrix are always zero. In addition, all relations in system dynamics are by their nature deterministic and for the most part time-invariant. The definition for the causal relation \mathfrak{R} can now be stated.

D8. *Causal relations.* A causal relation $\mathfrak{R}(\cdot, \cdot)$ is a deterministic relation satisfying properties (1) to (4) above.

A precise definitional understanding of the concepts relating to quantities within components and quantities between components is required. Previously, the notation Q_i and Q_b was introduced to denote quantities within component (i) and quantities at the interface between components respectively. In addition it is necessary to give special consideration to those

quantities in Q_i not directly associated with the flow – i.e. all quantities in Q_i except rates and stocks. Denoting these quantities as Q_{wi} , it should be apparent that $Q_{wi} = Q_i - S_i - R_i = P_i U_i V_i O_i$. The following definition is required for Q_{wi} .

D9. *Within-component quantities* Q_{wi} . Q_{wi} includes only those auxiliaries, outputs, inputs and parameters whose affector and effector subsets A_q and E_q are exclusively proper subsets of Q_i ; that is, $A_q(Q_{wi}) \cup E_q(Q_{wi}) \subseteq Q_i$. Thus only parameters, inputs, outputs and auxiliaries which pass information destined for rates within component (i) or receive information originating from stocks within component (i) are included within Q_{wi} . This definition is compatible with a previous discussion of these quantities in the main text of the paper.

The remaining between-component quantities Q_b are obviously those quantities left over from the set subtraction operation $Q - \bigcup_{i=1}^h Q_i$, if there are η components. The types of quantities included within Q_b will be taken up later as a theorem.

Axioms

This subsection relates the axioms necessary to formulate a system dynamics model using the component approach. These axioms are tautologous to notions popularized by Forrester [6]. The first axiom states the constituents used by Forrester to model a system.

A1. *Elements*. The basic components of a dynamic system can be modeled by means of the following quantity categories – stocks S , rates R , inputs U , outputs O , auxiliaries V , and parameters P – and by means of the following connector categories – flow F and information I . Specifically, the system is modeled by $M = \{B, Q, C\}$, where Q is the specified set of quantities, C is the specified set of connectors and B is the boundary of the system. Thus, $Q = SRUOPV$ and $C = FI$.

The next axiom is, perhaps, the most fundamental to the Forrester methodology and suggests the minimum ingredients necessary for loops.

A2. *Feedback*. Any feedback loop consists as a minimum of rate, flow connector, stock, information connector, and associated connectors, as depicted in Fig. 3 below.

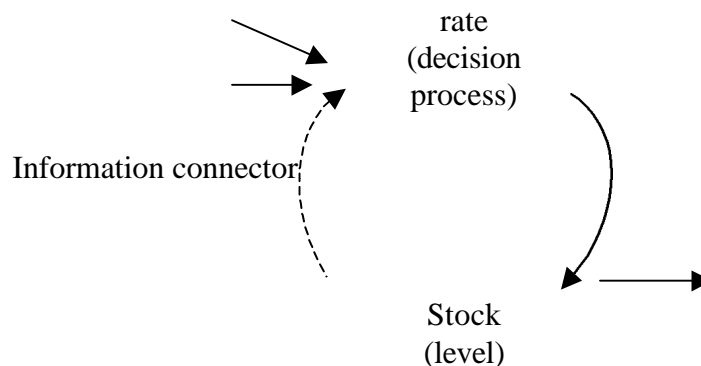

Figure 3. The feedback loop.

Although several other axioms are characteristic of system dynamics methodology, i.e. Burns [2], these two and the one that follows are the only ones necessary for the succeeding development.

A3. *Interaction between components.* By our definition of component there cannot be flows between components nor can there be components that are isolated (uncoupled) from all remaining components.

The first part of this axiom is a restatement of Principle 9-7 in Forrester [6], whereas the second part of the axiom can be inferred from Principle 4.1-1 of [6]. It is not useful to include within the boundary of the system a component that is uncoupled from other components. The component does not contribute to the dynamics of the other components nor are its dynamics in any way affected by the dynamics of the remaining components. Such a component is unrelated to the system and is said to be disjoint. Thus, it would be possible to partition the entire set of quantities Q into subsets Q_1, Q_2 , that are completely disjoint; that is $\mathfrak{R}(Q_1, Q_2) \cup \mathfrak{R}(Q_2, Q_1) = \hat{0}$. If the latter statements were true, then it would be possible to study the sets Q_1, Q_2 in complete isolation from each other. As a result of Axiom A3, information paths form the connecting tissue between components.

Theorems related to component approach

The theorems in this section are developed to maximize the inferences possible in filling the modified square ternary matrix. They will reduce the number of entries in the MSTM that the user has to consider in specifying the connectors among quantities whose identities are predetermined. The theorems are based on the primitives stated in section 1 of the paper. The first theorem below specifies the connectors types in the affector and effector sets of a quantity whose identity is known.

T1. Given a quantity q_j whose identity is known, then its associated connector subsets $E_c(q_j)$ and $A_c(q_j)$ are also known. Specifically,

- (a) For any $q_j \in S, A_c(q_j) \subseteq F \wedge E_c(q_j) \subseteq I$.
- (b) For any $q_j \in R, A_c(q_j) \subseteq I \wedge E_c(q_j) \subseteq F$.
- (c) For any $q_j \in V, A_c(q_j) \subseteq I \wedge E_c(q_j) \subseteq I$.
- (d) For any $q_j \in PU, A_c(q_j) = \hat{0} \wedge E_c(q_j) \subseteq I$.
- (e) For any $q_j \in O, A_c(q_j) \subseteq I \wedge E_c(q_j) = \hat{0}$.

P1. The theorem can be established provided each of the parts (a) to (e) are proven. Referring to the definitions given in section 1 for each quantity type, contraposition can be used for each part. Specifically, (a) is contrapositive to definition D3, (b) to D4, (c) to D5 (d) to D1 (e) to D2.

As an example of the utility of this theorem, suppose a particular quantity q_j shown in Fig. 2 has been identified. All other interaction shown in the row and column (of the STM) associated with q_j are also known. Specifically, if in Fig. 2, q_3 were identified as a stock, then all connectors shown in row 3 are information connectors and all connectors shown in column 3 are flow connectors. Each of the parts (a) to (e) in theorem T1 above can be depicted graphically as shown in Fig. 4 below.

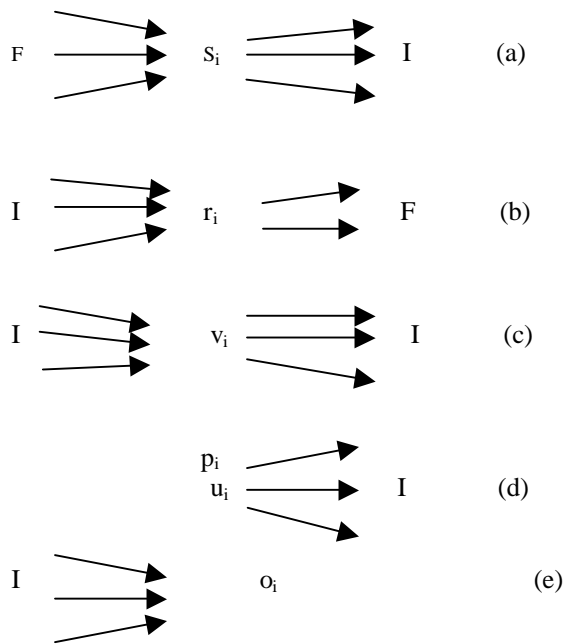

Figure 4. Adjacent Connector Interactions for each of the Quantity Types.

A consequence of the continuity proposition S1 is the following theorem stipulating when a quantity q_j is allowed to interact with another quantity q_k .

T2. A quantity q_j can potentially affect only those quantities q_k whose inward-directed connectors $A_c(q_k)$ are of the same type as the outward-directed connectors $E_c(q_j)$ of q_j . Conversely, q_j can only be affected by those quantities q_i whose outward-directed connectors $E_c(q_i)$ are of the same type as the inward-directed connectors $A_c(q_j)$.

P2. The proof follows from the fact that, in system dynamics, there are no restrictions as to what quantities can affect what other quantities, other than the very restriction mentioned in theorem T2. In the absence of any other restrictions, there are no counter examples or exceptions. If the theorem is true, then Fig. 4 suggests that the following interactions are possible:

R→S	S→O	S→R	S→V
	V→O	V→R	V→V
	P→O	P→R	P→V
	U→O	U→R	U→V

Here **R→S** is intended to suggest that rates could directly affect stocks only. A consideration of each of the interactions indicated above leads to the conclusion that all are possible. In the absence of exceptions, the claim of the theorem must be true.

The next theorem enables identification of the adjacent quantities contained in the subsets $A_q(q_i)$, $E_q(q_i)$ when the identify of q_i is known.

T3. If the type of quantity is known, then such knowledge imposes specific limitations upon the subsets $A_q(q_j)$, and $E_q(q_j)$ as follows:

- (a) If $q_j \in S$, then $A_q(q_j) \subseteq R \wedge E_q(q_j) \subseteq V R O$.
- (b) If $q_j \in R$, then $A_q(q_j) \subseteq S V P U \wedge E_q(q_j) \subseteq S$.
- (c) If $q_j \in V$, then $A_q(q_j) \subseteq S V P U \wedge E_q(q_j) \subseteq V R O$.
- (d) If $q_j \in PU$, then $A_q(q_j) = \hat{o} \wedge E_q(q_j) \subseteq V R O$.
- (e) If $q_j \in O$, then $A_q(q_j) \subseteq S V P U \wedge E_q(q_j) = \hat{o}$

P3. The theorem is established by proving each part separately. In (a), if $q_j \in S$, by T1 part (a), $A_c(q_j) \subseteq F$. However, as shown in Fig. 4, the only quantities q_i whose $E_c(q_i)$ are flow connectors are rates. Thus $A_q(q_j) \subseteq R$. Again, by T1 part (a), $E_c(q_j) \subseteq I$ and quantities affected by q_j through an information connector can be outputs $y_i \in O$, auxiliaries, $v_i \in V$, and rates $r_i \in R$ as depicted in Fig. 4. Hence $E_q(q_j) \subseteq O V R$ by T2, and part (a) is proven. Parts (b), (c), (d), and (e) of T3 are established using an identical procedure involving definitions D1 to D5, theorems T1 and T2 and Fig. 4.

In terms of the STM one effect of this theorem is, among other effects, the intimate interconnection between rates and stocks: along any row whose associated $q_j \in R$, those q_k for which $m_{jk} \neq 0$ must be stocks. Likewise, the entries along the column associated with any $q_j \in S$ for which $m_{ij} \neq 0$ must be rates.

Each of parts (a) to (e) in T3 could be more concisely written as the following corollary, in which $E_q(S)$ denotes the entire set of quantities affected by all quantities in S , and similarly for $E_q(I)$, $E_q(O)$, $E_q(U)$, $E_q(V)$, etc. An analogous notion is used to interpret $A_q(S)$, $A_q(I)$, $A_q(O)$, etc.

COR. For any quantity subset, the following statements are true:

- (a) $A_q(S) \subseteq R \wedge E_q(S) \subseteq V R O$;
- (b) $A_q(R) \subseteq S V P U \wedge E_q(R) \subseteq S$;
- (c) $A_q(V) \subseteq S V P U \wedge E_q(V) \subseteq V R O$;
- (d) $A_q(PU) = \hat{o} \wedge E_q(PU) \subseteq V R O$;
- (e) $A_q(O) \subseteq S V P U \wedge E_q(O) = \hat{o}$.

P. The proof follows directly from T3 and the fact that all quantities within a particular subset conform to the same rules for interaction as specified by T3.

The next theorem will use the causal relation \mathfrak{R} defined on the Cartesian product of a pair. The theorem is concerned with quantity subset pairs, i.e. (S, R) , (S, O) , (U, V) , etc.

T4. Given any quantity subset pair, the existence as well as the type of interaction (i.e. flow or information) that is possible for connectors directed from quantities in the first member of the pair toward quantities within the second member of the pair, is known. Specifically:

(a) For the Cartesian product pairs $S \times P$, $S \times U$ and $S \times S$ no connectors exist; that is $\mathfrak{R}(S, P) = \mathfrak{R}(S, U) = \mathfrak{R}(S, S) = \hat{o}$, in which $\mathfrak{R}(,)$ denotes the set of connectors between subset pairs. On the other hand information connector subsets can exist for pairs $S \times R$, $S \times V$ and $S \times O$; thus, $\mathfrak{R}(S, R) \cup \mathfrak{R}(S, V) \cup \mathfrak{R}(S, O) \subseteq I$.

(b) For the Cartesian product pairs $R \times V$, $R \times P$, $R \times U$, $R \times O$ and $R \times R$ no connectors exist; that is $\mathfrak{R}(R, V) = \mathfrak{R}(R, P) = \mathfrak{R}(R, U) = \mathfrak{R}(R, R) = \hat{o}$. On the other hand, a flow connector subset exists for $R \times S$; thus $\mathfrak{R}(R, S) \subseteq F$.

(c) For the Cartesian product pairs $V \times S$, $V \times P$, and $V \times U$ no connectors exist; that is, $\mathfrak{R}(V, S) = \mathfrak{R}(V, P) = \mathfrak{R}(V, U) = \hat{o}$. On the other hand, information connector subsets can exist for $V \times R$, $V \times V$ and $V \times O$; thus, $\mathfrak{R}(V, R) \cup \mathfrak{R}(V, V) \cup \mathfrak{R}(V, O) \subseteq I$.

(d) For the Cartesian product pairs $P \times S$, $P \times U$, and $P \times P$ no connectors exist; that is, $\mathfrak{R}(P, S) = \mathfrak{R}(P, U) = \mathfrak{R}(P, P) = \hat{o}$. On the other hand, information connector subsets can exist for $P \times R$, $P \times V$, and $P \times O$; thus $\mathfrak{R}(P, R) \cup \mathfrak{R}(P, V) \cup \mathfrak{R}(P, O) \subseteq I$.

(e) For the Cartesian product pairs $U \times S$, $U \times P$, and $U \times U$ no connectors exist; that is, $\mathfrak{R}(U, S) = \mathfrak{R}(U, P) = \mathfrak{R}(U, U) = \hat{o}$. On the other hand, information connector subsets can exist for $U \times R$, $U \times V$, and $U \times O$; thus $\mathfrak{R}(U, R) \cup \mathfrak{R}(U, V) \cup \mathfrak{R}(U, O) \subseteq I$.

(f) For the Cartesian product pair $O \times Q$, where $Q = S R V P U O$ no connectors exist; that is $\mathfrak{R}(O, Q) = \hat{o}$.

P4. The theorem can be established, provided each of its constituent parts are substantiated. Consider first part (a) of T4. It should be apparent that $\mathfrak{R}(S, P) = \mathfrak{R}(S, U) = \hat{o}$ because neither P nor U can have connectors directed toward quantities contained in their subsets. The fact that $\mathfrak{R}(S, S) = \hat{o}$ follows from COR, part (a) which states that $E_q(S) \subseteq V R O$. Thus $\mathfrak{R}(S, P) = \mathfrak{R}(S, U) = \mathfrak{R}(S, S) = \hat{o}$. However, $\mathfrak{R}(S, V R O)$ does contain connectors and $\mathfrak{R}(S, V R O) = \mathfrak{R}(S, V) \cup \mathfrak{R}(S, R) \cup \mathfrak{R}(S, O)$, all of which must be information connectors. Parts (b), (d), (e), and (f) are established using an identical rationale.

T4 can be used effectively in filling the modified STM (square ternary matrix). Figure 5 shows a MSTM (modified square ternary matrix) with connector subset types deliberately designated. Empty spaces of the matrix refer to the nonexistence of connectors among quantity subset pairs. A large number of entries in the MSTM obviously can be inferred – in fact, all boxes left blank contain entries which are known to be blank or zero. These inferences and previous specification of connector types also ensure correct Forrester schematics for the system. The model-maker must concern himself only with those submatrices in the MSTM where the connector subset types are specified as $\pm F$ or $\pm I$. The MSTM of Fig. 5 could represent the interactions within a single component or an entire system.

	S	R	V	PU	O
S		$\pm I$	$\pm I$		$\pm I$
R	$\pm F$				
V		$\pm I$	$\pm I$		$\pm I$
PU		$\pm I$	$\pm I$		$\pm I$
O					

Figure 5. Inferences possible in a component (subsystem) matrix **A**.

The matrix depicted in Fig. 5 is referred to as the component matrix. Entries and non-entries along row S are justified by T4, part (a), while entries along row R are justified by T4, part (b), etc.

Next, the interconnection matrix is considered. The matrix is redrawn in Fig. 6, where for convenience it is indexed by the sets S_i, R_i, Q_{wi} along its column and by the sets S_j, R_j, Q_{wj} along its row. (Recall that, by definition, $Q_{wi} = P_i U_i V_i O_i$.) Clearly from D9, (Q_{wi}, Q_j) is null since it is impossible for quantities inside Q_{wi} to affect quantities outside component i . By the same token, (Q_i, Q_{wj}) is also null. Thus

	S_j	R_j	Q_{wj}
S_i		$\pm I$	
R_i			
Q_{wi}			

Figure 6. Inferences possible in the interconnection matrix **B**

all portions of the interconnection matrix are blank except possibly the matrix indexed by $S_i R_i, S_j R_j$. Consider the $S_i \times S_j$ submatrix; by T4 part (a). $(S_i, S_j) = \emptyset$, and this submatrix is blank. Likewise by T4 part (b). (R_i, R_j) is null and its corresponding submatrix is blank. This leaves only the submatrices $S_i \times R_j$ and $R_i \times S_j$. Considering theorem T4 part (b), the only connectors directed from rates to stocks are flow connectors. However a flow connector directed from a rate of one component toward a stock of another component would violate the definition of a component, as stipulated by the following theorem.

T5. The rates of component i , $q_j \in R_i$, $j = 1, \dots, m_i$, $i = 1, \dots, n$, can be coupled through flow connectors, $c_{jk} = (q_j, q_k) \in F$, *only* with the stocks of component i , $q_k \in S_i$, but not with the stocks of the other components of the system.

P5. The definition of components identifies each component with a different flow of substance within the component. Hence the rates of one component cannot influence the stocks of any other component except of its own.

Clearly, then (R_i, S_j) is null and the only submatrix left to consider is $S_i \times R_j$. By T4 part (a), $(S, R) \subseteq I$, thus the only non-blank submatrix in the interconnection matrix is the $S_i \times R_j$ submatrix which can potentially contain information connectors.

Now, consider the following lemma.

L6. The only quantities that could conceivably comprise the set of between-component quantities Q_b are auxiliaries V_b , parameters and inputs PU_b , and outputs O_b .

P6. If the set of quantities Q_b contains stocks S or rates R , then a flow exists outside of those components previously identified for the problem, and a new component must be defined for the newly identified flow. This is necessarily consistent with the adopted convention which stipulates that wherever a flow exists, a component must be defined for that flow (see Axiom A3). This result will be used in the discussion to follow.

In addition to the matrices labeled **A** and **B** there is a need to rationalize the matrices labeled **C**, **D**, and **E** in the interaction matrix. Consider first the interface matrix **C**. For convenience matrix **C** is pictured in Fig. 7 below where it is indexed by S_i , R_i , Q_{wi} along its column and by V_b , PU_b , O_b along its row. The matrix is sparse in the sense that it contains few non-blank entries. By virtue of the fact that $E_q(Q_{wi}) \subseteq Q_i$, $(Q_{wi}, Q_b) = \hat{0}$ by definition and all rows associated with Q_{wi} are zero. Likewise, the row associated with R_i must be zero as $(R_i, Q_b) = \hat{0}$. This follows directly from theorem T5 which R_i is shown to be incapable of affecting quantities outside its own component.

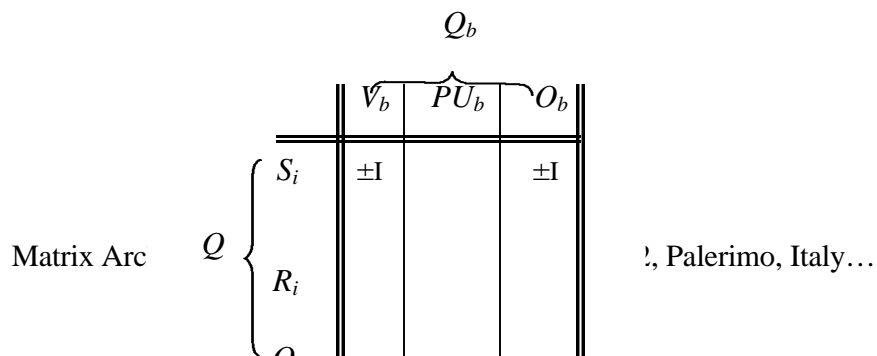

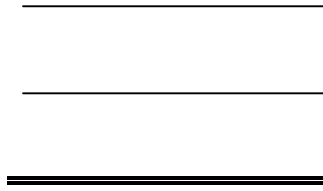

Figure 7. The interface matrix **C**.

Thus only the row associated with S_i remains undiscussed. Since parameters and inputs are unaffected by anything, $(S_i, PU_b) = \hat{0}$. However, it would be entirely possible for stocks S_i to be affected by auxiliaries V_b and outputs O_b by means of information connectors, as stipulated by theorem T4. Such deliberations are sufficient to rationalize the insertion of entries within the interface matrix **C** as depicted in Fig. 7 above.

Consider next the interface matrix **D**. Its appearance is, for convenience, depicted in Fig. 8 below where it is indexed by V_b, PU_b, O_b along its column, and by S_i, R_i, Q_{wi} along its row. As in the case of previously considered matrices, the matrix is sparse. Since $E_q(O_b) = \hat{0}$, $(O_b, Q_i) = \hat{0}$ and the row associated with O_b contains no non-zero entries. Also, by our convention

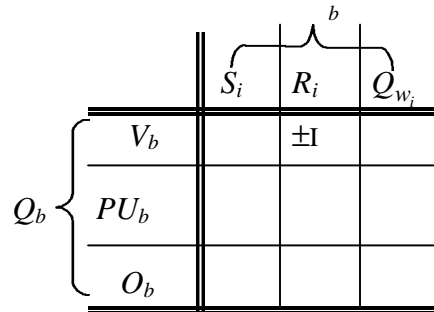

Figure 8. The interface matrix **D**.

between-component parameters and inputs PU_b will not affect any quantities outside of the set of between-component quantities Q_b . A parameter or input which affects quantities within Q_b and any Q_i must be defined twice, using different symbolic designations. This very situation occurred in the example treated in the companion paper [3] in which ‘initial gas reserves’ was given a p_4 designation for its inclusion within component S_2 and a p_5 designation for its inclusion in the set of between-component quantities Q_b . Consequently $(PU_b, Q_i) = \hat{0}$ and the middle row in the interface matrix **D** contains no non-zero entries.

Only the row associated with S_i remains undiscussed. By T4, $R(V_b, S_i) = \hat{0}$ as auxiliaries cannot affect stocks. By our convention, $(V_b, Q_{wi}) = \hat{0}$; that is, between-component quantities cannot affect within-component quantities Q_{wi} , as this violates the definition provided for quantities Q_{wi} . The only submatrix in which connectors might occur is within the (V_b, R_i)

submatrix; theorem T4 does allow for interactions directed from auxiliaries toward rates. In fact, the entire between-component structure must reside on an information path that originates at a stock in one component and terminates at a rate within another component. Thus the only feasible interactions from quantities within Q_b to quantities within Q_i are information connectors contained within the (V_b, R_i) submatrix.

Finally, the interface matrix \mathbf{E} will be rationalized. The matrix is indexed by V_b , PU_b , and O_b along both its row and column as shown in Fig. 9 below. The matrix exhibits the interactions possible for quantities within Q_b . As such the matrix conforms exactly to the rules of interaction provided by theorem T4. By T4, part (c), information connector subsets exist for the sub-matrices associated with the products $V \times V$ and $V \times O$, and the submatrix associated with the product $V \times P$, $V \times U$ (i.e. the (V_b, PU_b) submatrix) is empty. By T4, part (f),

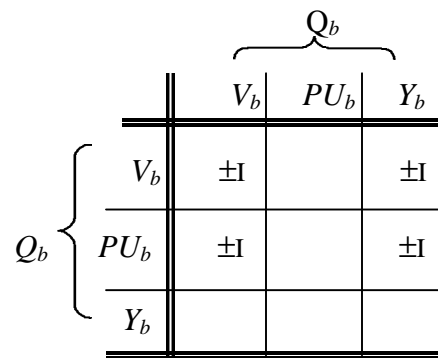
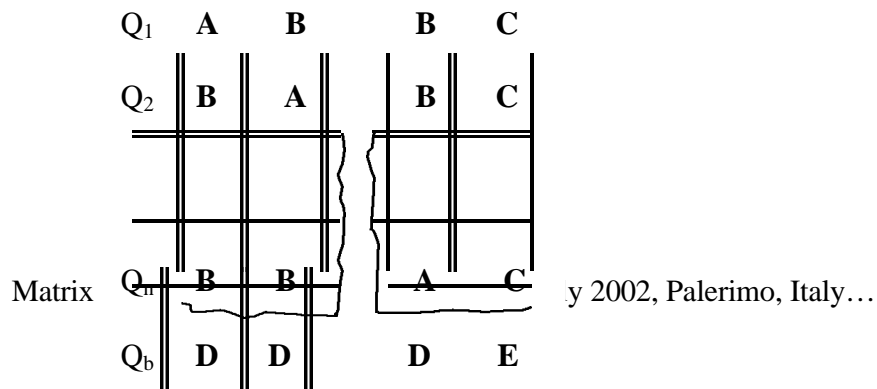

Figure 9. The interface matrix \mathbf{E} .

all submatrices associated with O_b are zero. And by T4, parts (d) and (e), the submatrix (PU_b, PU_b) is empty, while the submatrices (PU_b, V_b) and (PU_b, O_b) may have information connectors within them.

This is sufficient to rationalize the structural format of the interaction matrix. Certainly, the appearance of the interaction matrix is strongly influenced by the conventions that were adopted. For example, the definition of Q_{wi} and the implication of that definition upon Q_b strongly determines where interactions will take place. Since all auxiliaries, parameters, inputs, and outputs are contained within the sets Q_b and $Q_w \left(= \bigcup_{i=1}^n Q_{wi} \right)$ which themselves are mutually exclusive, it is possible to partition Q such that $\Pi_Q = \{S; R; Q_b; Q_w\}$. By definition D9, $(Q_b, Q_w) \cup (Q_w, Q_b) = \hat{o}$ and accounts for many of the vacancies in the



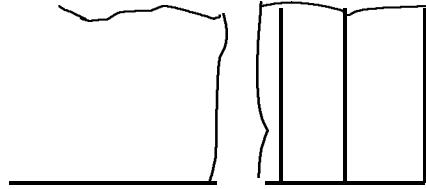

Figure 10. The n -component interaction matrix.

The generalization of the matrix depicted in Fig. 10 to 3, 4 and n components is a straightforward analytic exercise that will not be treated here. In Figure 10 above, Q_n is the set of quantities associated with the n -th subsystem or component. If all between-component quantities are grouped together under the name Q_b , the interaction matrix for n components assumes the form exhibited in Fig. 10 above, where **A**, **B**, **C**, **D**, and **E** are the previously defined matrices.

Conclusion. The matrix architecture presented in this paper offers several advantages over conventional approaches. First, it limits the interaction possibilities amongst the quantities to those that are governed by the rules, axioms of system dynamics as originally set forth by Forrester. Particularly, for model developers that are relatively new to the discipline, this can be a considerable advantage—like placing training wheels on a person who is just learning to ride a bike. The matrix architecture prevents interactions that are inconsistent with basic system dynamics constructs. Thus, the architecture can prevent errors of commission.

Similarly, the interaction matrix suggests where interactions are likely to occur. In that sense, the architecture prevents errors of omission by focusing the developer's attention on those interaction possibilities that are most-likely to occur—the nonblank cells in the interaction matrix.

The interaction matrix is a compact way to present the rules of interaction that are possible in system dynamics. As such, there may be some disagreement amongst practitioners as to whether the rules imposed by the interaction matrix represent reality or not. In that sense, the interaction matrix is a good vehicle for dialogue and discussion about what interactions should be allowed, especially for novice users.

REFERENCES

- [1] BURNS, J.R., 1976, "A Preliminary Approach to Automating the Process of Simulation Model Synthesis," *Proceedings of the Seventh Annual Pittsburgh Conference on Modeling and Simulation* (Pittsburgh: Instrument Society of America). P. 820.
- [2] BURNS, J.R., 1977, "Converting Signed Digraphs to Forrester Schematics and Converting Forrester Schematics to Differential Equations," *I.E.E.E. Trans, Syst., Man, Cybernet.*, **7**, 695.
- [3] BURNS, J.R., & Ulgen, O., *A Component Strategy for the Formulation of System Dynamics Models*, Proceedings of the System Dynamics Society, Palerimo, Italy, July 2002.
- [4] FITZ, R., and Hornbach, D., 1976, "A Participative Methodology for Designing Dynamic Models Through Structural Models," *Proceedings of the seventh Annual Pittsburgh Conference of Modeling and Simulation* (Pittsburgh: Instrument Society of America), p. 1168.
- [5] FORRESTER, J.W., 1961, *Industrial Dynamics* (Cambridge: M.I.T. Press).
- [6] FORRESTER, J.W., 1968, *Principles of Systems* (Cambridge: Wright-Allen Press).
- [7] FORRESTER, J.W., 1969, *Urban Dynamics* (Cambridge: M.I.T. Press).
- [8] FORRESTER, J.W., 1971, *World Dynamics* (Cambridge: Wright-Allen Press).
- [9] FORRESTER, N.B., 1973, *The Life-Cycle of Economic Development* (Cambridge: Wright-Allen Press).
- [10] GOODMAN, M.R., 1974, *Study Notes in System Dynamics* (Cambridge : Wright-Allen Press).
- [11] HARARY, R., NORMAN, R., and CARTWRIGHT, D., 1965, *Structural Models: An Introduction to the Theory of Directed Graphs* (New York: John Wiley).
- [12] KANE, J., 1972, "A Primer for a new Cross-impact Language KSIM," *Tech. Forecast. Social Change*, **4**, 129.
- [13] KLIR, G.J., 1969, *An Approach to General Systems Theory* (New York: Van Nostrand-Reinhold).
- [14] MOLL, R.H., and WOODSIDE, C.M., 1976, TR No. S.E. 76-1, Systems Engineering Department, Carleton University, Toronto, Canada.
- [15] THESEN, A., 1974, "Some Notes on Systems Models and Modeling," *Int. J. Systems Sci.*, **5**, 145.

[16] WAKELAND, W., 1976, "A Low-budget Heuristic Approach to Modeling and Forecasting," *Tech Forecast. Social Change*, **9**, 213.

[17] WARFIELD, J., 1976, *Societal Systems* (New York: Wiley-Interscience).